

**2025**

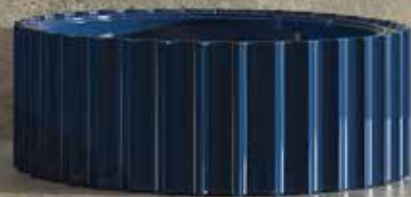

**→ FLAMINIA.**



**Flaminia70**  
pag. 2

---

**Configuratore**  
pag. 4

---

**Norma**  
pag. 6

---

**Settecento Cut**  
pag. 8

---

**Falala**  
pag. 10

---

**Siena**  
pag. 12

---

**Monotwin Slim Stripes**  
pag. 14

---

**Link 51**  
pag. 16

---

**AppLight**  
pag. 18



# ➔ FLAMINIA.70





➔ **FLAMINIA.CULTURA**

## FLAMINIA 70 anni di ceramica

Augusto Ciarrocchi

La storia della Ceramica Flaminia affonda le sue radici nella primavera del 1954, quando un gruppo di operai ceramisti decise di dar vita a una nuova azienda per la produzione di articoli sanitari. Da allora l'azienda è divenuta la più longeva tra quelle ancora attive nel distretto di Civita Castellana, attraversando trasformazioni, sfide e successi che riflettono l'evoluzione di un intero territorio.

Questo volume nasce con l'intento di raccontare, senza enfasi celebrative, un percorso fatto di lavoro, passione e continuità. La narrazione ripercorre i decenni iniziali della produzione, segnati da metodi artigianali e ambienti di lavoro duri, nei quali l'abilità manuale e la fatica quotidiana erano protagoniste. Si mette così in luce un mondo ormai scomparso, fissandone la memoria prima che venga dispersa.

Ampio spazio è dedicato ai primi anni, ai documenti e alle testimonianze dirette, ma anche alla vita più recente dell'azienda, affrontata con sguardo il più possibile oggettivo. Viene inoltre tracciato un legame con le tante realtà industriali del distretto civitonico, alcune tuttora in attività, altre ormai scomparse sotto la pressione della competizione internazionale.

Il libro vuole essere, al tempo stesso, un omaggio a tutti coloro che hanno contribuito con il proprio lavoro alla lunga storia della Flaminia e un documento prezioso per comprendere come tradizione e innovazione abbiano convissuto e si siano intrecciate nel corso di settant'anni di attività.

*The history of Ceramica Flaminia began in the spring of 1954, when a group of ceramic workers decided to establish a new company for the production of sanitary ware. Since then, the company has become the longest-standing among those still active in the Civita Castellana district, going through transformations, challenges, and successes that reflect the evolution of an entire territory.*

*This volume was conceived with the aim of narrating a journey built on work, passion, and continuity, without resorting to celebratory tones. The story retraces the early decades of production, marked by artisanal methods and harsh working environments where manual skill and daily effort played a central role. In doing so, it seeks to preserve the memory of a world that has now disappeared, before it is irretrievably lost. Great attention is dedicated to the early years, to documents and first-hand testimonies, but also to the company's more recent history, approached with a balanced and critical outlook. The narrative also highlights the strong connection with many other industries of the Civita Castellana district, some still in operation and many others that have disappeared under the pressure of national and international competition.*

*At the same time, the book stands as a tribute to all those who, through their work, have contributed to the long history of Flaminia, and as a valuable record of how tradition and innovation have coexisted and intertwined throughout seventy years of activity.*

# IL NUOVO CONFIGURATORE BAGNO: DESIGN E TECNOLOGIA A PORTATA DI CLIC

THE NEW BATHROOM CONFIGURATOR:  
DESIGN AND TECHNOLOGY AT YOUR FINGERTIPS

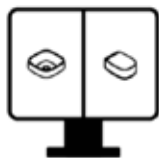

CONFIGURAZIONE SIMULTANEA  
SIMULTANEOUS CONFIGURATION

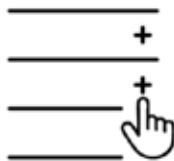

SCELTA GUIDATA  
GUIDED SELECTION



REALTÀ AUMENTATA  
AUGMENTED REALITY



DISTINTA SCARICABILE  
DOWNLOADABLE LIST

Da sempre sinonimo di innovazione per l'ambiente bagno, Flaminia continua a guidare il cambiamento con uno strumento dedicato a privati, progettisti e rivenditori: il configuratore on line per il bagno.

Pensato per offrire un'esperienza d'acquisto coinvolgente, intuitiva e personalizzata, consente con pochi clic di arredare il proprio bagno con i prodotti del marchio, combinandoli in tempo reale per valutarne l'effetto d'insieme. Il sistema mostra due viste separate, una per l'area lavabo e una per quella dei sanitari, permettendo così di ottenere una visione completa e coerente dell'ambiente. La navigazione è guidata passo dopo passo: si seleziona la collezione, poi il modello e il colore, infine si completa la composizione con rubinetteria e accessori. Una delle novità più interessanti è la personalizzazione simultanea delle due zone principali del bagno, ma il vero punto di forza è rappresentato dalla possibilità di visualizzare il risultato in realtà aumentata. Dopo aver configurato i prodotti, basta uno smartphone per vedere l'ambiente configurato prendere forma direttamente nel proprio spazio, ovunque ci si trovi. Una funzione utile e divertente che permette al cliente di scegliere con maggiore consapevolezza, rendendo ogni decisione più concreta e ragionata. Alla fine del processo si può scaricare un documento con l'elenco dei prodotti scelti, completi di codici e finiture.

Il configuratore è accessibile liberamente dal sito Flaminia ed è consultabile da pc, smartphone e tablet.

*Flaminia has always been a synonym of innovation in bathroom sector and now it continues to lead change with a dedicated tool for private customers, designers, and retailers: the bathroom configurator available online.*

*Designed to provide an engaging, intuitive, and customized experience, it allows users to furnish their own bathroom with Flaminia products in just a few clicks, combining them in real time to evaluate the overall effect. The system displays two separate views—one for the washbasin area and one for the sanitaryware—ensuring a complete and coherent vision of the environment. Navigation is guided step by step: at first you can select the collection, then the model and colour, and finally you can complete the composition with taps and accessories.*

*One of the most interesting new features is the simultaneous customization of the two main bathroom areas, but the real strong point is the possibility to view the result in augmented reality. After having configured the products, a smartphone is all you need to see your bathroom becoming reality directly in its own space, wherever you are. A useful and amazing feature that allows clients to choose being well informed, making each decision clearer and well thought. At the end of the process, a document can also be downloaded with the list of selected products, complete with codes and finishes.*

*The configurator is free on Flaminia website and it can be used from PC, smartphone, and tablet.*



Scopri di più  
*Discover more*



# NORMA

Elena Salmistraro



**Norma** \_ Smeraldo  
art. NA70CSME - 70 x 50 x h 94 cm

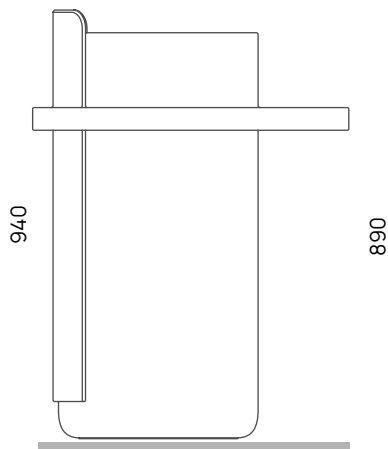
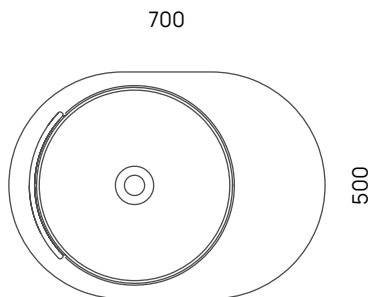

Il lavabo free standing Norma, dalla forte presenza e dall'importante impatto estetico, è caratterizzato da forme morbide e plastiche: una colonna a cilindro sostiene una conca che poggia su un comodo piano.

L'inserimento di un piano d'appoggio in questa tipologia di lavabi rappresenta un'innovazione significativa a livello funzionale e pratico.

Norma, disegnato da Elena Salmistraro, è realizzato in due pezzi ed è proposto in vari colori. Un lavabo a colonna che da solo diventa protagonista assoluto dell'ambiente bagno.

*Norma free-standing washbasin, with its bold presence and striking aesthetic impact, is defined by soft and sculptural lines: a cylindrical column supports a basin benched on a useful top.*

*The integration of a countertop in this kind of washbasin represents a significant functional and practical innovation.*

*Designed by Elena Salmistraro, Norma is composed of two pieces and available in a variety of colours.*

*A column washbasin that, on its own, becomes the absolute protagonist of the bathroom.*



**Norma\_ Metal Platino**  
art. NA70CPLA  
70 x 50 x h 94 cm

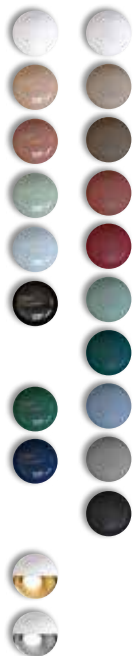

La fortunata famiglia di lavabi Settecento di Giulio Cappellini per Flaminia si completa con un nuovo elemento: Settecento Cut. Questo prodotto da appoggio è una sezione del lavabo da terra Monosettecento.

Questa serie di lavabi, dalle forme classiche e tondeggianti, si rifa' alle acquasantiere delle chiese barocche del Settecento. Settecento Cut viene proposto in una serie di vibranti e sofisticati colori sia opachi che lucidi che enfatizzano la tridimensionalità di questo oggetto che conferma l'abilità produttiva di Flaminia.

*The successful Settecento washbasin collection by Giulio Cappellini for Flaminia is enriched with a new element: Settecento Cut.*

*This bench basin is realized as a section of the floor-standing Monosettecento washbasin.*

*Characterized by classic, rounded forms, this line gets inspiration from the holy water font of 18th century baroque churches.*

*Settecento Cut is available in a wide palette of vibrant and sophisticated colours, both matte and glossy, which enhance the three-dimensionality of this piece, confirming Flaminia's production ability.*



**Settecento Cut** \_ Argilla  
art. SECUTARG - ø 44 x h 16 cm

440

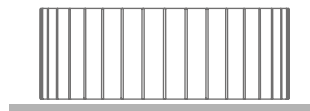
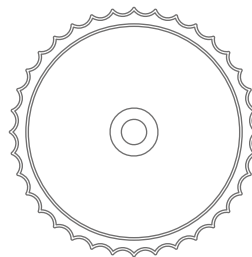

160

# SETTECENTO CUT

Giulio Cappellini



Settecento Cut \_ Topazio  
art. SECUTTOP - ø 44 x h 16 cm

# FALALA

Elena Salmistraro



Falala \_ Topazio  
art. FA46ATOP - ø 46 x h 15,5 cm



Il particolare rilievo puntinato del lavabo da appoggio Falala esalta la plasticità della materia ceramica e indaga il tema della tridimensionalità. Ispirato alle borse in paglia africane, ha una forma morbida e avvolgente e l'originale texture trasforma questo oggetto di uso quotidiano in un pezzo unico. Disponibile in vari colori lucidi e opachi, Falala viene realizzato anche nella particolare finitura Crystal che crea un originale effetto chiaro-scuro.

*The particular dotted relief of Falala countertop washbasin enhances the ceramic plasticity and explores the theme of three-dimensionality. Inspired by traditional African straw bags, this product presents a soft, enveloping form, while its original texture transforms an everyday object into a unique design element.*

*Available in a wide range of glossy and matte colours, Falala is also produced in the special Crystal finish, which creates an original light-and-shadow effect.*

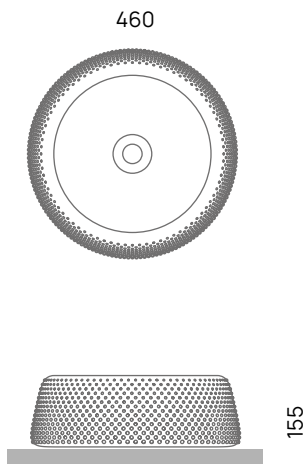



**Siena \_ Cenere**  
art. SN46ACEN - ø 46 x h 15 cm

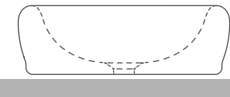
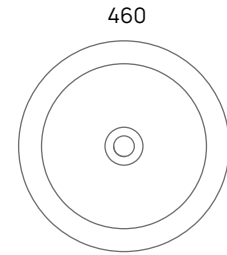

Siena è uno studio sulla morbidezza e la sua forma sinuosa prende spunto dalle dolci linee delle colline toscane. Disegnato dal giovane designer indiano Gupta, è un lavabo da appoggio dal segno continuo e fluido che conferisce al volume equilibrio e raffinatezza.

La forma armoniosa è esaltata anche dal dettaglio della base che trasmette stabilità all'oggetto e ne arricchisce la silhouette.

*Siena is a study on softness. Its sinuous shape is inspired by the gentle lines of the Tuscan hills. Designed by the young Indian designer Gupta, it is a countertop washbasin, with a continuous and fluid line that gives balance and refinement to the volume.*

*The harmonious shape is also enhanced by the detail of the base that transmits stability to the object and enriches its silhouette.*



**Siena \_ Terracotta**  
art. SN46ATC - ø 46 x h 15 cm

# SIENA

Advay Gupta

**Siena** \_ Avana  
art. SN46AAV - ø 46 x h 15 cm



Il lavabo freestanding della collezione Twin, firmata da Ludovica e Roberto Palomba, diventa bicolore con le nuove finiture Stripes Argilla/Carbone, Latte/Carbone, Argilla/Fango, Fango/Carbone già presenti a catalogo per la collezione Flag e il nuovo abbinamento Cenere/Carbone.

*Monotwin, the freestanding washbasin from the Twin collection designed by Ludovica and Roberto Palomba, is now available in a two-tone version. The new finishes include Stripes Argilla/Carbone, Latte/Carbone, Argilla/Fango, and Fango/Carbone—already featured in the Flag collection—as well as the new Cenere/Carbone combination.*

**MonoTwin Slim**  
Fango+Carbone  
art. MTR42CSFC - ø 42 x h 90 cm



ARGILLA  
CARBONE



ARGILLA  
FANGO



CENERE  
CARBONE



FANGO  
CARBONE



LATTE  
CARBONE



# MONOTWIN SLIM STRIPES

L+R Plaomba



**MonoTwin Slim**  
Cenere+Carbone  
art. MTC42PSCC - ø 42 x h 90 cm

# LINK 51

G. Cappellini e R. Palomba



Link 51 goclean | Plusssystem \_ Bianco  
art. LK119RG-LKCW09 / LK219  
51 x 36 x h 43 cm

L'iconica collezione Link, disegnata da R. Palomba e G. Cappellini, si amplia con una versione compatta back to wall con profondità 51 cm. Con ben 5 cm in meno rispetto ai modelli già presenti a catalogo per questa linea, questi sanitari possono essere inseriti anche in ambienti dalle dimensioni ridotte. La Link 51 è disponibile in vari colori lucidi e opachi con il sistema goclean Plus (per ristrutturazioni).

*The iconic Link collection, designed by R. Palomba and G. Cappellini, expands with a compact back-to-wall version with a 51 cm depth. With 5 cm less compared to the existing models of this line, these sanitaryware can also be installed in smaller bathroom spaces.*

*Link 51 is available in a variety of glossy and matte finishes and is equipped with the goclean Plus system, making it particularly suitable for renovation projects.*

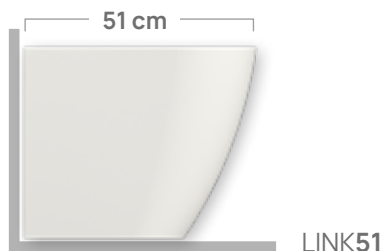



60

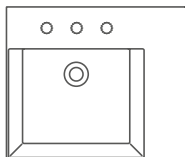

51

70

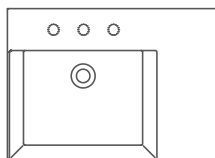

51

85

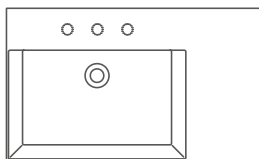

51

105

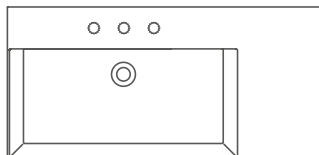

51



**AppLight 7051** \_ Bianco  
art. AP7051 - 70 x 51 x h 12 cm

**Cubika 51** \_ Verde Palude  
art. CKD913LVK - 70 x 51 x h 78,5 cm

I nuovi AppLight con profondità 51 sono disponibili in 4 misure - da cm 60, 70, 85 e 105 - e solo con piano in ceramica a destra. Possono essere installati sospesi, in appoggio e su mobile, in quest'ultimo caso il lavabo sostituisce completamente il top.

L'abbinamento è possibile con le basi portalavabo a terra e sospese, solo con cassetti, della collezione Cubika e con la struttura portalavabo Denver in tutte le finiture previste.

The new 51cm-deep AppLight basins are available in four sizes—60, 70, 85, and 105cm—with a ceramic top on the right only. They can be wall-hung, countertop, or vanity; in this case the sink replaces completely the countertop.

They can be combined with the collection's floor-standing and wall-mounted vanity units, with drawers only, of the Cubika collection and with Denver vanity unit in all available finishes.

# APPLIGHT

Flaminia Design Team



**AppLight 6051** \_ Bianco  
art. AP6051 - 60 x 51 x h 12 cm

**Cubika 51** \_ Fokos Terra  
art. CKDI02GTK - 60 x 51 x h 78,5 cm



**AppLight 105** \_ Bianco  
art. AP10551 - 105 x 51 x h 12 cm

**Denver** \_ Verde Palude  
art. DV105SLVK - 102 x 50 x h 75,5 cm

**AppLight 85** \_ Cenere  
art. AP8551 - 85 x 51 x h 12 cm

**Cubika 51** \_ Fokos Sale  
art. CKD919GSK - 85 x 51 x h 78,5 cm



**AppLight 8551** \_ Bianco  
art. AP8551 - 85 x 51 x h 12 cm

**Cubika 51** \_ Fokos Sale  
art. CKD879GSK - 85 x 51 x h 50 cm





# Le certificazioni Certifications



Il marchio **Italy<sup>x</sup>** certifica l'italianità delle imprese sulla base del Disciplinare Tecnico, sviluppato da Il Sole 24 Ore ed è rilasciato alle aziende che producono esclusivamente in Italia. Questa certificazione, istituita in partnership con Confindustria, mira ad attribuire valore e dare visibilità alle imprese che incarnano e rappresentano i valori dell'italianità, sotto l'aspetto societario, produttivo e progettuale.

The **Italy<sup>x</sup>** mark certifies the Italian nature of companies on the basis of the Technical Specifications, developed by Il Sole 24 Ore and it is issued to those companies that produce exclusively in Italy. This certification, created in partnership with Confindustria, aims to attribute value and give visibility to companies that embody and represent the values of Italianness, from a corporate, production and planning perspective.

Il SOLE 24 ORE

CONFININDUSTRIA



Certified Italian Excellence - ITALYX



Environmental Management System  
UNI EN ISO 14001

## Quality Management System UNI EN ISO 9001

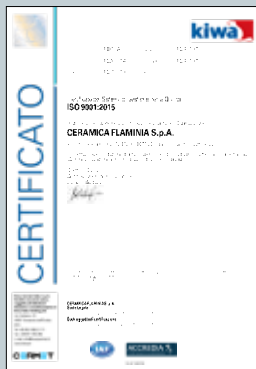

Energy Management System  
UNI EN ISO 50001



**Ceramics of Italy** è il marchio che rappresenta l'industria ceramica italiana. La definizione "Made in Italy" non identifica solo una connotazione geografica, ma racchiude in sé i valori riconosciuti all'industria italiana in tutto il mondo: qualità, trasparenza, leadership nel design, innovazione, sostenibilità ambientale e responsabilità sociale. Il prestigioso marchio d'origine, ideato da Confindustria Ceramica, può essere apposto solo sui prodotti effettivamente realizzati in Italia.

**Ceramics of Italy** is the mark representing the Italian ceramic industry. The definition "Made in Italy" identifies not only a geographical connotation, but also embodies the values recognized to the Italian industry throughout the world: quality, transparency, leadership in design, innovation, environmental sustainability and social responsibility. The prestigious mark of origin, created by Confindustria Ceramica, can only be affixed to products actually made in Italy.

#ioscelgoresponsabile  
#Ichooseresponsible

Scopri di più sulla sostenibilità  
della Ceramica Italiana



# La Ceramica Italiana. **Io scelgo la responsabilità.**

Italian Ceramics. **I choose responsibility.**



  
CONFINDUSTRIA CERAMICA

“  ”  
Ceramics of Italy  
for Sustainability

ceramica.info

Copyright  
**Flaminia 2025**

Art direction  
**Giulio Cappellini**

Photo  
**Roberto Costantini**



➔ **FLAMINIA.**

**Spazio Flaminia Showroom**

via Solferino, 18 - Milano

t. +39 02 89055303 f. +39 02 89055490

spazioflaminia@ceramicaflaminia.it

**Ceramica Flaminia Spa**

Via Flaminia km. 54,630 - Civita Castellana VT

t. +39 0761 542030 f. +39 0761 540069

ceramicaflaminia@ceramicaflaminia.it



**2025**



**→ FLAMINIA.**