

Unique pools

Hotel & Spa | 2026

by  ROSA
GRES



04

Proyectos
Projects
Projets

68

Servicios
Services
Services

74

Seguridad
Security
Sécurité

80

Nuevo pavimento drenante
New draining pavement
Nouvelle chaussée drainante

84

Colores
Colors
Couleurs

94

Sistemas constructivos, piezas especiales
Construction systems, trim pieces
Systèmes de construction, pièces spéciales

114

Cocina industrial
Industrial kitchen
Cuisine industrielle

118

Sostenibilidad
Sustainability
Durabilité

123

Características técnicas
Technical characteristics
Caractéristiques techniques

Bienvenidos a **Unique Pools Hotel & Spa 2026**: un viaje por todo el mundo a través de los hoteles que han confiado en nuestro gres porcelánico para crear sus espacios.

En esta edición, te presentamos nuestras últimas novedades: los 8 colores de **Cuore, Sophy y Coral**; un sistema desbordante único, el **Minimal System**; nuevos formatos, el **metro por metro** y las **piezas de 2 cm de grosor**; soluciones constructivas, como el **Ergo Plus System** y diversas piezas especiales, que perfeccionan el acabado de los proyectos de piscina.

Queremos inspirarte e invitarte a confiar en nuestro equipo. Te acompañamos con auténtica ilusión y con el espíritu de colaboración que nos define como empresa.

En **Rosa Gres** ecodiseñamos todos nuestros productos y sistemas constructivos para reducir su impacto ambiental.

Calidad, resistencia, funcionalidad, creatividad y sostenibilidad son los valores que guían la creación de cada una de nuestras soluciones. **Todo pensado para crear detalles únicos, confort y la máxima seguridad para vuestros huéspedes.**

Nos encantará compartir contigo lo que hemos aprendido a lo largo de más de 50 años explorando nuevos proyectos en todo el mundo. Porque **sabemos, como tú, que cada Hotel es una experiencia única, un Hotel único.**

Gracias por estar aquí.

Welcome to **Unique Pools Hotel & Spa 2026**: a journey around the world through the hotels that have trusted in our porcelain stoneware to create their spaces.

In this edition, we bring you our latest innovations: the eight colors of **Cuore, Sophy and Coral**; a unique overflow system, the **Minimal System**; new formats, **meter by meter** and **2 cm thick pieces**; construction solutions, such as the **Ergo Plus System**; and various trim pieces to give your pool projects the perfect finishing touch.

We want to inspire you and invite you to place your trust in our team. We accompany you every step of the way in your projects with genuine enthusiasm and the spirit of collaboration that defines us as a company.

At **Rosa Gres** we ecodesign all our products and construction systems in a way that reduces their environmental impact.

Quality, durability, functionality, creativity and sustainability are the values that guide the creation of each and every one of our solutions. **All designed to create unique features, comfort and maximum safety for your guests.**

We cannot wait to share with you the things we have learned over the course of 50 years of exploring new projects all over the world. Because, like you, **we know that every Hotel is a unique experience, a unique Hotel.**

Thank you for being here.

Bienvenus dans **Unique Pools Hotel & Spa 2026** : un voyage dans le monde entier à la découverte des hôtels qui ont fait confiance à notre grès cérame pour créer leurs espaces.

Dans cette édition, nous vous présentons nos toutes dernières nouveautés : les 8 couleurs de **Cuore, Sophy et Coral** ; un système à débordement unique, le **Minimal System** ; de nouveaux formats, tels que le carré d'un **mètre sur un mètre** et les **pièces de 2 cm d'épaisseur** ; des solutions de construction, comme **Ergo Plus System** et diverses pièces spéciales qui permettent de perfectionner la finition des projets de piscine.

Nous voulons être une source d'inspiration et vous invitons à faire confiance à notre équipe. Nous vous accompagnons sur chaque projet avec l'enthousiasme authentique et l'esprit de collaboration qui sont les traits caractéristiques de notre entreprise.

Chez **Rosa Gres**, tous nos produits et systèmes de construction sont éco-conçus afin de réduire leur impact sur l'environnement.

Qualité, solidité, fonctionnalité, créativité et durabilité sont les valeurs qui guident la création de tous nos solutions. **Tous ces éléments sont conçus pour créer des détails uniques, un confort et une sécurité maximale pour vos hôtes.**

Nous sommes heureux de partager avec vous ce que nous avons appris au cours de plus de 50 ans d'exploration de nouveaux projets dans le monde entier. Parce que **nous savons, comme vous, que chaque hôtel est une expérience unique, un hôtel unique.**

Nous vous remercions d'être là.

























































































































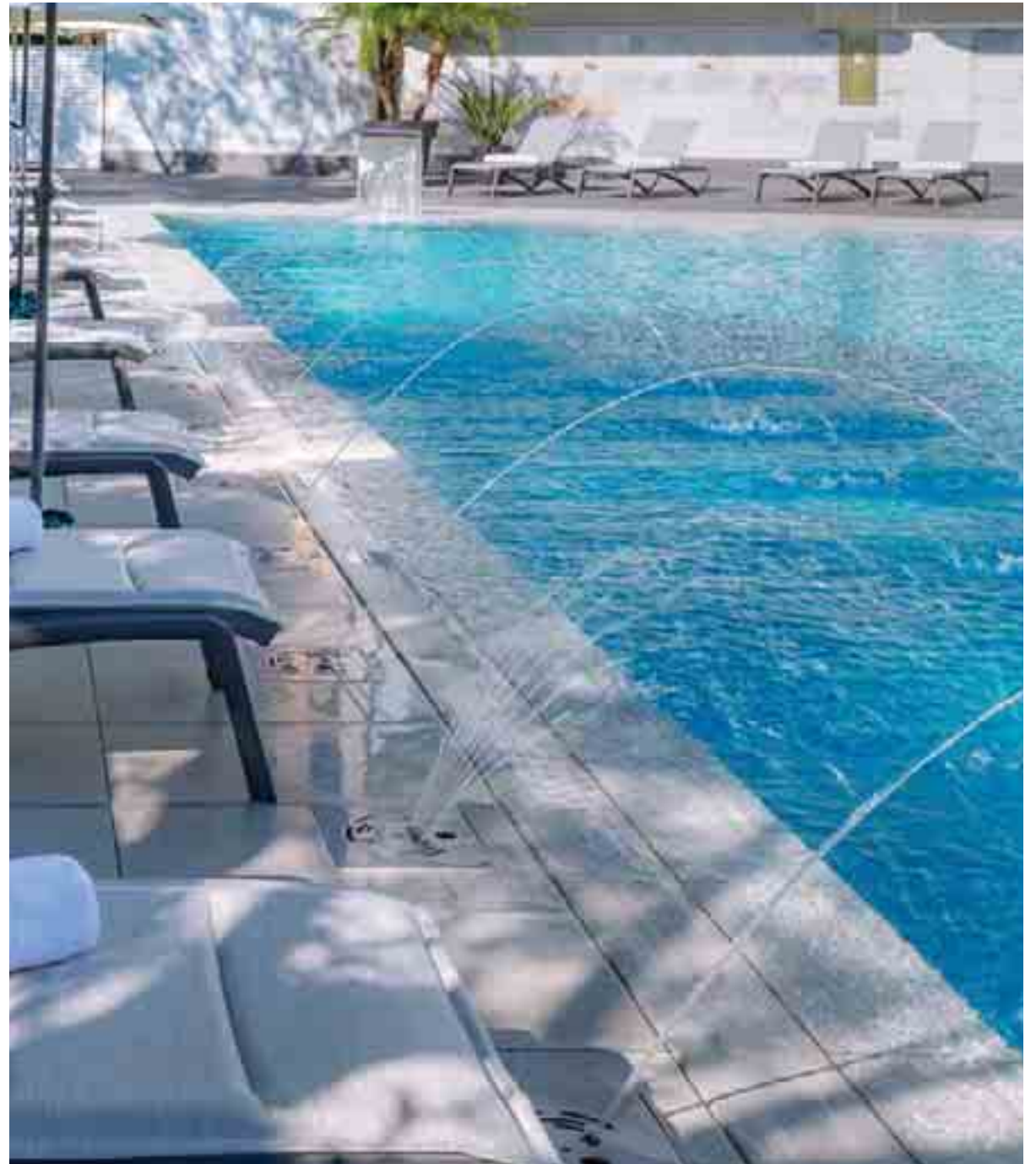











IMPLICADOS COMO UN VERDADERO PARTNER

Nuestro equipo técnico es experto en desarrollo y construcción de piscinas. Trabajamos con metodología BIM. Asesoramos a los profesionales y arquitectos durante todo el proceso constructivo.

FULLY INVOLVED LIKE A TRUE PARTNER

Our technical team are experts in the design and construction of swimming pools. We work with BIM methodology. We consult with contractors and architects throughout the construction process.

S'IMPLIQUER EN TANT QUE VERITABLE PARTENAIRE

Notre équipe technique est experte dans le développement et la construction de piscines. Nous travaillons avec la méthodologie BIM. Nous conseillons les professionnels et les architectes tout au long du processus de construction.





**DESCUBRE NUESTRA
ZONA PROFESIONALES**

**DISCOVER OUR
PROFESSIONALS AREA**

**DÉCOUVREZ NOTRE
ESPACE PROFESSIONNEL**



RECURSOS BIM + CAD
BIM + CAD RESOURCES
RESSOURCES BIM + CAD



**SISTEMAS CONSTRUCTIVOS
PARA PISCINAS**

CONSTRUCTION SYSTEMS
FOR POOLS

SYSTÈMES DE CONSTRUCTION
POUR PISCINES



**COLORES Y TEXTURAS
DESCARGABLES**

COLORS AND TEXTURES
AVAILABLE FOR DOWNLOAD

COULEURS ET TEXTURES
TÉLÉCHARGEABLES



**FICHAS TÉCNICAS
Y MEMORIAS DESCRIPTIVAS**

TECHNICAL DATA SHEETS AND
SPECIFICATIONS

FICHES TECHNIQUES ET
MÉMOIRES DESCRIPTIVES

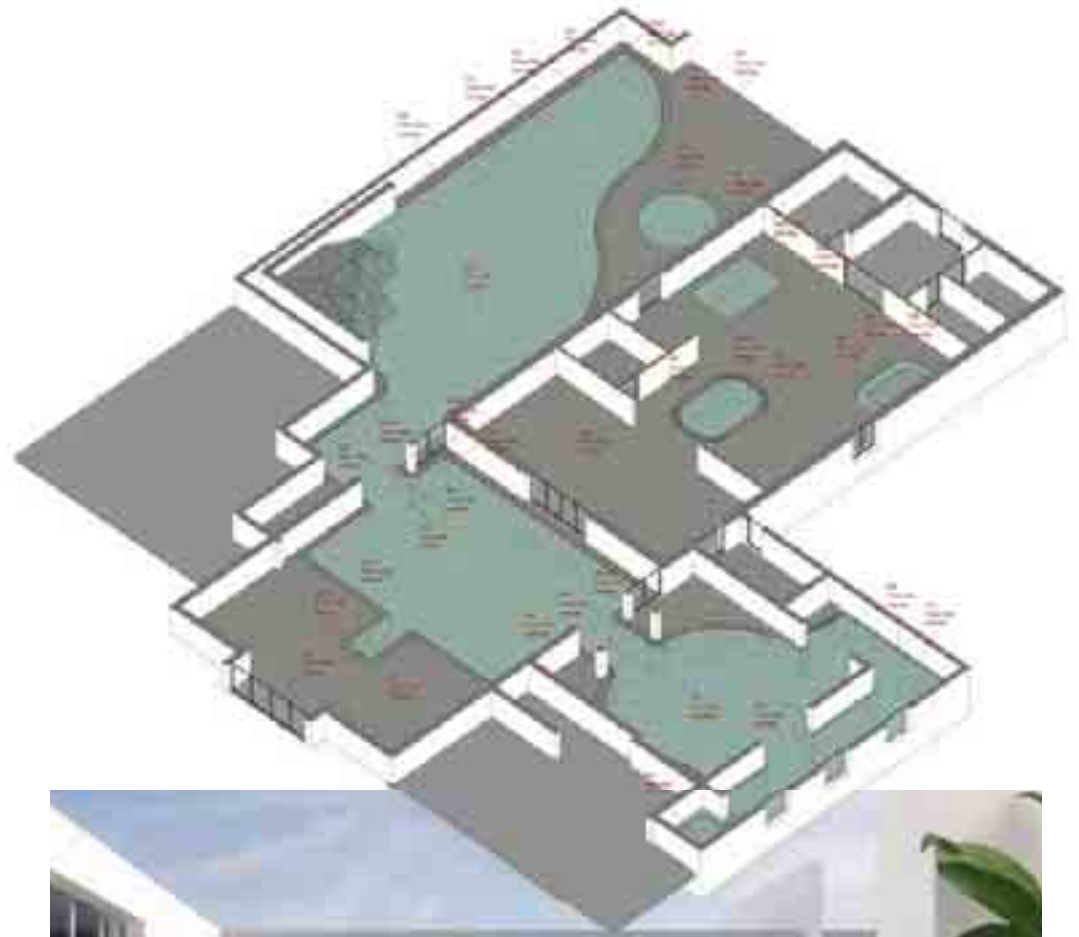

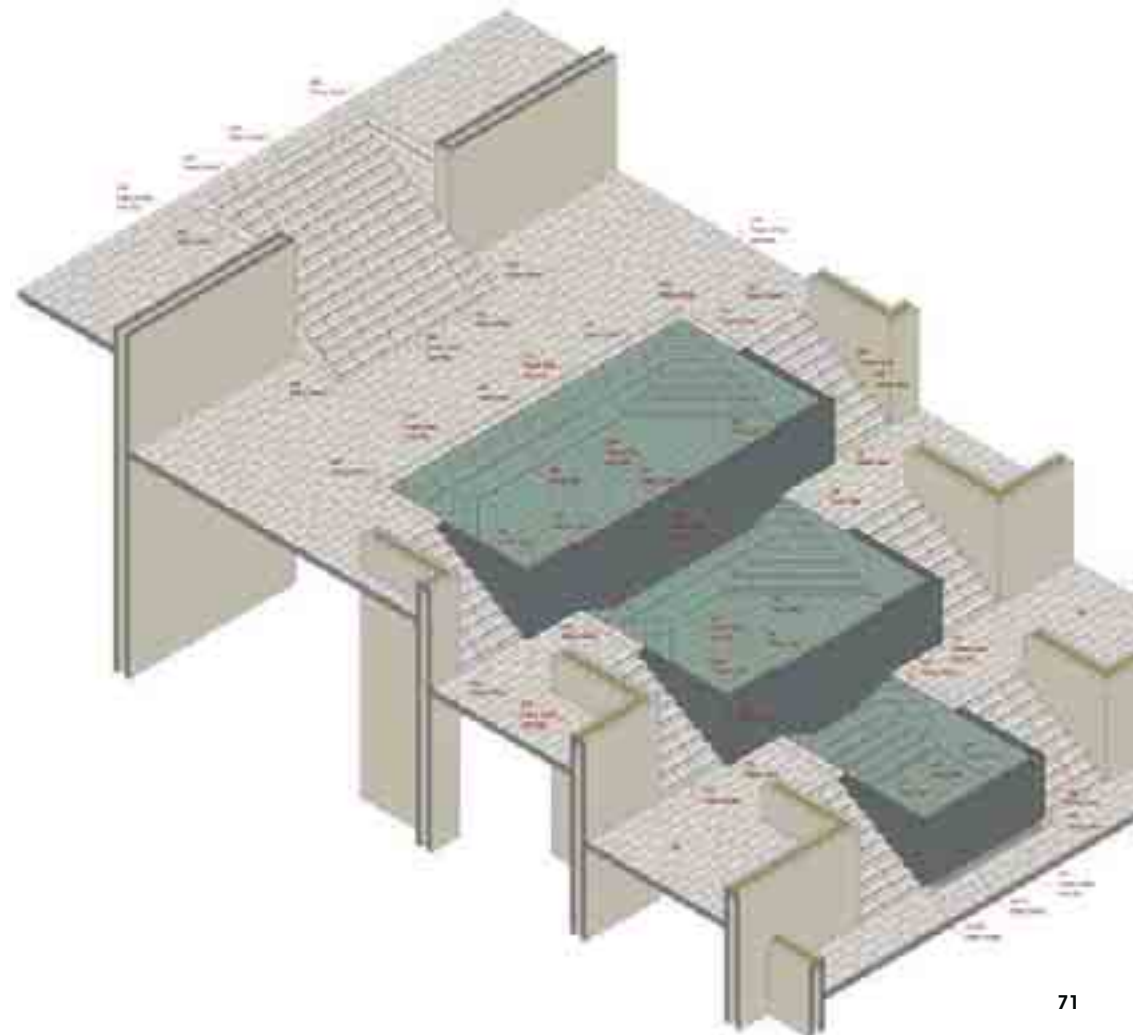

dream team



DISEÑAR, PROYECTAR CONSTRUIR, DISFRUTAR

Para conseguir un acabado perfecto es imprescindible trabajar con las mejores soluciones constructivas. Sabemos que cada diseño es único. Contar con la experiencia de los productos **Fixcer** para la construcción nos garantiza el éxito final de todo el proyecto.

DESIGN, PLAN, BUILD, ENJOY

Achieving the perfect finish is only possible with the best construction solutions. We know that each design is unique. Trust in the expertise of **Fixcer** products for construction guarantees the success of the entire project.

CONCEVOIR, PLANIFIER CONSTRUIRE, APPRÉCIER

Pour obtenir une finition parfaite, il est essentiel de travailler avec les meilleures solutions de construction. Nous savons que chaque projet est unique. Faites confiance à l'expérience des produits **Fixcer** pour la construction garantit le succès final de l'ensemble du projet.

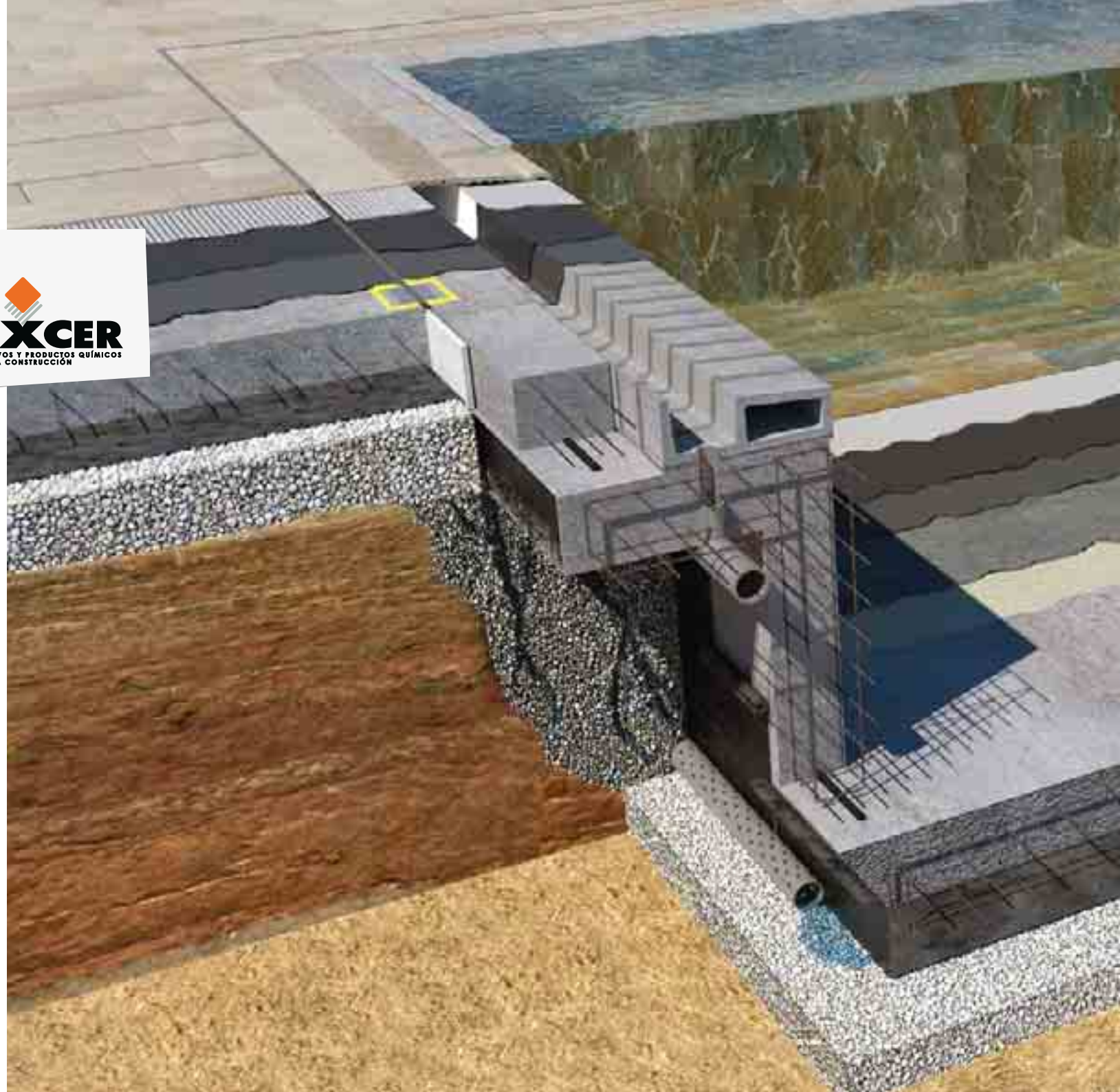



zero problems pools

- PEGAR
- REJUNTAR
- IMPERMEABILIZAR
- SELLAR
- FIXING
- GROUTING
- WATERPROOFING
- SEALING
- COLLER
- JOINTOYER
- IMPERMÉABILISER
- SCELLER



ZERO FUGAS
PISCINA 100% ESTANCA
ZERO LEAKS
100% WATERTIGHT POOLS
ZÉRO FUITE
PISCINE 100% ÉTANCHE

MÁS DE 1.000.000 de m²
DE PISCINAS REALIZADOS
OVER 1,000,000 m²
OF POOL INSTALLATIONS
PLUS DE 1.000.000 m²
DE PISCINES RÉALISÉES

CONSUMO DEL AGUA
MÁS SOSTENIBLE
MORE SUSTAINABLE
USE OF WATER
UTILISATION PLUS
RESPONSABLE DE L'EAU

LA SOLIDEZ CONSTRUCTIVA
ALARGA LA VIDA DE LA PISCINA
SOLID CONSTRUCTION FOR GREATER
DURABILITY
LA SOLIDITÉ DE LA CONSTRUCTION
PROLONGE LA DURÉE DE VIE DE LA PISCINE

REDUCCIÓN DE LOS COSTES
DE MANTENIMIENTO
REDUCED
MAINTENANCE COSTS
RÉDUCTION DES
COÛTS D'ENTRETIEN

FABRICACIÓN SOSTENIBLE
NORMA EN14.001
SUSTAINABLE MANUFACTURING
STANDARD EN14.001
FABRICATION DURABLE
NORME EN14.001

MAXIMUM SAFETY

Rosa Gres fabrica uno de los acabados antideslizantes de gres porcelánico más seguros del mercado. Es agradable al tacto y fácil de limpiar. **¿Cómo funciona?** Al pisar el pavimento húmedo se produce un efecto ventosa y de agarre al suelo que evita el deslizamiento

Rosa Gres produces one of the safest non-slip porcelain stoneware surfaces on the market. It is pleasant to the touch and easy to clean. **How does it work?** When stepping on the wet tile, it produces a suction and grip effect that prevents slipping.

Rosa Gres fabrique l'un des revêtements de sol antidérapants en grès cérame les plus sûrs du marché. C'est un matériau agréable au toucher et facile à nettoyer. **Comment fonctionne-t-il ?** Le fait de marcher sur le sol mouillé produit un effet d'aspiration et d'adhérence qui empêche de glisser.





SOLAR REFLEC TANCE IRS

El gres porcelánico Rosa Gres expuesto a la luz del sol presenta un excelente comportamiento atérmico. En todos los casos, los colores claros se calientan menos que los colores oscuros.

Rosa Gres porcelain stoneware has excellent Solar Reflectance Index. Lighter colors always heat up less than darker colors.

Le grès cérame Rosa Gres exposé à la lumière du soleil a un excellent comportement thermique. Dans tous les cas, les couleurs claires se réchauffent moins que les couleurs foncées.

MAXIMUM SECURITY

NUEVO ACABADO ANTIDESLIZANTE PASTILLA

Nuevos colores con el acabado pastilla. Es ideal para zonas con tránsito descalzo y presencia de agua. Con los nuevos colores, el acabado pastilla se viste de diseño.

NEW NON-SLIP "PASTILLA" FINISH

New colors available with the diamond finish. Ideal for areas with barefoot traffic and the presence of water. These new colors add a designer touch to the Pastilla finish.

NOUVELLE FINITION ANTIDÉRAPANTE "PASTILLA"

Nouvelles couleurs avec la finition structurée. Elle est idéale pour les zones où l'on circule pieds nus et où il y a de l'eau. Avec les nouvelles couleurs, la finition tablette s'habille de design.





Pietro White Pastilla 31 x 62,6



Pietro Golden Pastilla 31 x 62,6



Pietro Grey Pastilla 31 x 62,6



Pietro Dark Pastilla 31 x 62,6



Iconic White Pastilla 31 x 62,6



Iconic Grey Pastilla 31 x 62,6

EN 16165
(DIN 51097)
Anexo A

CLASE C
≥ 24°

EN 16165
(DIN 51130)
Anexo B

R11
> 19° - 27°

DIN 51130

V4

EN 16165
(AN. 2.6)
Anexo c

CLASE 3
RD > 45

EVITA
EL EFECTO
"AQUAPLANING"
CON PIE
DESNUDO

ELIMINATE THE
AQUAPLANING
EFFECT WITH
BARE FEET

CELA PERMET
D'ÉVITER
"L'AQUAPLANING"
PIEDS NUS

New Format 2 cm thick

NEW!

PIEZAS DE 2 cm DE GROSOR

Ideal para combinar con el peldaño L98
y el coronamiento BR6 / BR9.

PIECES WITH A THICKNESS OF 2 cm

Perfect to combine with the L98 step
and the BR6 / BR9 edge pieces.

PIÈCES DE 2 cm D'ÉPAISSEUR

Idéal pour assortir à la marche L98
ainsi qu'au couronnement BR6 / BR9.



BR9 Anti-slip
97,9 x 50 x 2,6



L98 Anti-slip
97,9 x 31,7 x 3,8

50M 2 cm



2 cm



Iconic White Anti-slip
48,8 x 97,9 x 2

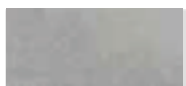

Iconic Grey Anti-slip
48,8 x 97,9 x 2



Pietro White Anti-slip
48,8 x 97,9 x 2



Pietro Golden Anti-slip
48,8 x 97,9 x 2



Colocación en seco sobre hierba, arena o gravilla.
Dry placement on grass, sand or gravel.
Pose à sec sur gazon, sable ou gravier.
Posa a secco su erba, sabbia o ghiaia.
Colocação a seco sobre relva, areia ou gravilha.
Trockenverlegung auf Gras, Sand oder Kies.



Colocación sobre plots.
Placement on plots.
Pose sur plots.
Posa su piedi d'appoggio.
Colocação sobre plots.
Verlegung auf Stelzlager.



ECO design

Draining pavement



NUEVO PAVIMENTO DRENANTE DE DISEÑO

- No rompe el ciclo del agua
- No necesita pendientes ni canalizaciones
- Alta capacidad drenante
- Juntas resistentes, sin mantenimiento
- Acabado porcelánico de diseño Rosa Gres

NEW DESIGNER FLOORING WITH DRAINAGE

- Does not disrupt the water cycle
- No need for slopes or channels
- High drainage capacity
- Durable joints, no maintenance
- Rosa Gres designer porcelain stoneware finish

SOL PER CHAUSSÉE DRAINANTE NOUVELLE CONCEPTION

- Ne rompt pas le cycle de l'eau
- Pas besoin de pentes ou de canalisations
- Grande capacité de drainage
- Joints résistants sans entretien
- Finition en grès cérame design Rosa Gres



1

Sanear y nivelar el terreno.
Colocar la capa de grava.

Prepare and level the site.
Lay the gravel.

Nettoyer et niveler le sol.
Poser la couche de gravier.



2

Aplicar MORTER DRAIN regleado encima de la grava.

Apply MORTER DRAIN over the gravel.

Appliquer MORTER DRAIN sur le gravier.



3

Una vez aplicado dejar fraguar el mortero, cubriéndolo con un plástico durante 48 horas.

Once applied, leave the mortar to set and cover with plastic for 48 hours.

Une fois le mortier appliqué, il faut le laisser durcir en le recouvrant d'un film plastique pendant 48 heures.



4

Pegar las piezas de Gres porcelánico con cemento cola FIXAFLEX GEL manteniendo el ancho de la junta necesario según los requisitos de drenaje previstos.

Fix the porcelain stoneware pieces with FIXAFLEX GEL tile adhesive, maintaining the required joint width according to the drainage requirements.

Coller les pièces en grès cérame avec le ciment-colle FIXAFLEX GEL en respectant la largeur de joint nécessaire en fonction des exigences de drainage.



5

Pasadas 24 horas rejuntar con JUNTA DRAIN.

After 24 hours, grout with JUNTA DRAIN.

Après 24 heures, jointoyer avec JUNTA DRAIN



6

Al cabo de 24 horas el suelo ya es totalmente utilizable.

Flooring is fully usable after 24 hours.

Après 24 heures, le sol est entièrement utilisable.



¿Cómo funciona?
VER VÍDEO

How does it work?
WATCH VIDEO

Comment cela
fonctionne-t-il ?
VOIR LA VIDÉO

CONSTRUCCIÓN INDUSTRIALIZADA DE PISCINAS
 INDUSTRIALIZED POOL CONSTRUCTION
 CONSTRUCTION INDUSTRIALISÉE DE PISCINES



SISTEMA 9

Coronamiento prefabricado formado por bloques de hormigón hidrófugo. Cada pieza funciona como canal y soporte de la cerámica. Se integra perfectamente con todos nuestros Sistemas Desbordantes.

THE 9 SYSTEM

Prefabricated overflow channel of water resistant concrete blocks. Each piece acts as a channel and support for the ceramic tile. Integrates perfectly with all our overflow systems.

SYSTÈME 9

Canal fabriqué en blocs de béton hydrofuges. Chaque pièce sert de canal et de support pour les céramiques. Elle s'intègre parfaitement à tous nos systèmes à débordement.



AHORRO DE TIEMPO, MANO DE OBRA Y RECURSOS

SAVINGS IN TIME, LABOR AND RESOURCES

ÉCONOMISER DU TEMPS, DE LA MAIN-D'ŒUVRE ET DES RESSOURCES



EL SISTEMA DE COLOCACIÓN REDUCE LA CREACIÓN DE RESIDUOS

PLACEMENT SYSTEM REDUCES WASTE

LE SYSTÈME DE PLACEMENT RÉDUIT LA PRODUCTION DE DÉCHETS



ACABADO PERFECTO DE LA CORONACIÓN DE LA PISCINA

PERFECT FINISH FOR THE POOL COPING

FINITION PARFAITE DE LA MARGELLE DE LA PISCINE



ELIMINA LAS DEFICIENCIAS PRODUCIDAS POR EL ENCOFRADO

ELIMINATES DEFECTS CAUSED BY THE FORMWORK

ÉLIMINE LES DÉFICIENCES CAUSÉES PAR LE COFFRAGE



AUMENTA LA ESTÉTICA VISUAL Y EL BIENESTAR

ENHANCES VISUAL AESTHETICS AND COMFORT

AMÉLIORE L'ESTHÉTIQUE VISUELLE ET LE BIEN-ÊTRE



ZERO FUGAS. MÁS HIGIENE. MENOS PRODUCTOS PARA LA DEPURACIÓN

ZERO LEAKS, IMPROVED HYGIENE, FEWER PURIFICATION PRODUCTS

ZÉRO FUITE. PLUS D'HYGIÈNE. MOINS DE PRODUITS DE PURIFICATION.



ENCAJA CON LAS MÚLTIPLES PIEZAS DE ACABADO ROSA GRES

COMPATIBLE WITH A WIDE RANGE OF ROSA GRES FINISHING PIECES

S'ADAPTE AUX MULTIPLES PIÈCES DE FINITION ROSA GRES



LA CERÁMICA ROSA GRES AUMENTA EL CICLO DE VIDA DE LA PISCINA

ROSA GRES STONEWARE PROLONGS THE LIFE OF THE POOL

LA CÉRAMIQUE ROSA GRES AUGMENTE LA DURÉE DE VIE DE LA PISCINE



100% ESTANCA.
SIN FUGAS. GARANTIZADO.

100 % WATERTIGHT.
NO LEAKS. GUARANTEED.

100 % ÉTANCHE.
SANS FUITE. GARANTI.



PRESUPUESTO
SIN "SORPRESAS"

QUOTATION WITHOUT
ANY "SURPRISES"

DEVIS
"SANS SURPRISE"



MÁXIMA
DURABILIDAD

MAXIMUM
DURABILITY

DURABILITÉ
MAXIMALE



EJECUCIÓN EN
TIEMPO RÉCORD

PROJECT COMPLETION
IN RECORD TIME

EXÉCUTION EN
UN TEMPS RECORD



MAYOR INERCIA
TÉRMICA

INCREASED
THERMAL INERTIA

INERTIE THERMIQUE
RENFORCÉE



MÁXIMA PRECISIÓN
EN LA EJECUCIÓN

MAXIMUM PRECISION IN
CONSTRUCTION

PRÉCISION MAXIMALE DANS
L'EXÉCUTION



HOMOLOGACIÓN
FINA GARANTIZADA

GUARANTEED
FINA COMPLIANCE

HOMOLOGATION
FINA GARANTIE



MENOS RECURSOS
MENOS RESIDUOS

FEWER RESOURCES,
LESS WASTE

MOINS DE RESSOURCES
ET MOINS DE DÉCHETS

SISTEMA 10

Un innovador sistema constructivo que permite construir Piscinas Desbordantes de Hormigón mediante bloques prefabricados en un tiempo récord y con todas las garantías.

THE 10 SYSTEM

An innovative construction system that allows the construction of concrete overflow pools with prefabricated blocks in record time and with all the guarantees.

SYSTÈME 10

Un système de construction innovant qui permet de réaliser des piscines à débordement en béton à partir de blocs préfabriqués en un temps record et avec toutes les garanties.

colors & water colors

Los colores del agua son orientativos

Water colors are indicative

Les couleurs de l'eau sont indicatives

Juntas de colocación
Fixcer recomendadas

Recommended Fixcer
Grouting color

Joint d'installation
Fixcer recommandés

IDEAL COLOR

| | | | |
|--|-------------------|--|-------------------|
| | 0 Blanco | | 0 Blanco |
| | 1 Beige | | 1 Beige |
| | 8 Gris claro | | 8 Gris claro |
| | 9 Gris cemento | | 9 Gris cemento |
| | 10 Antracita | | 10 Antracita |
| | 11 Negro | | 11 Negro |
| | 25 Humo | | 46 Piedra |
| | 28 Plomo | | 48 Marrón arena |
| | 29 Perla | | |
| | 40 Blanco Miami | | |
| | 46 Piedra | | |
| | 48 Marrón arena | | |

CERPOXI / PROFESSIONAL PX

| | |
|--|-------------------|
| | 0 Blanco |
| | 2 Beige oscuro |
| | 3 Beige Natural |
| | 4 Marrón claro |
| | 8 Gris Claro |
| | 9 Gris cemento |
| | 10 Antracita |
| | 11 Negro |

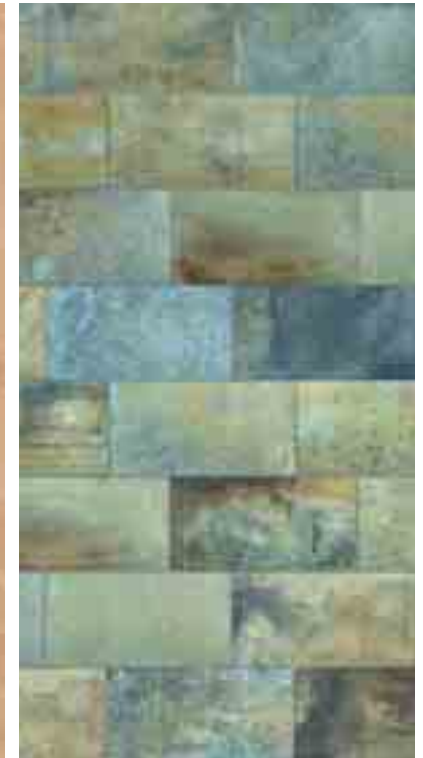

Cuore Beige NEW!

97,9 x 97,9 x 1 Liso Rectificado ⁽¹⁾
 97,9 x 97,9 x 1 Anti-slip Rectificado ⁽²⁾
 48,8 x 97,9 x 1 Liso Rectificado ⁽¹⁾
 48,8 x 97,9 x 1 Anti-slip
 31 x 62,6 x 0,9 Anti-slip

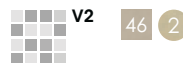

Cuore Rosso NEW!

97,9 x 97,9 x 1 Liso Rectificado ⁽¹⁾
 97,9 x 97,9 x 1 Anti-slip Rectificado ⁽²⁾
 48,8 x 97,9 x 1 Liso Rectificado ⁽¹⁾
 48,8 x 97,9 x 1 Anti-slip
 31 x 62,6 x 0,9 Anti-slip



Cuore Verde NEW!

31 x 62,6 x 0,9 Anti-slip
 31,3 x 31,3 (4,9 x 4,9 / u) Mosaico Anti-slip ⁽³⁾

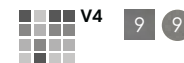

⁽¹⁾Smooth - Rectified / Lisse - Rectifié ⁽²⁾Anti-slip - Rectified / Anti-slip - Rectifié ⁽³⁾Mosaico enmallado de gres porcelánico / Porcelain mesh-mounted mosaic tiles / Mosaïque sur maille en grès cérame

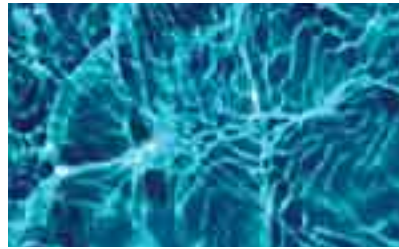
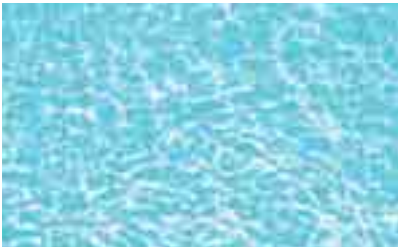

Sophy White NEW!

97,9 x 97,9 x 1 Liso Rectificado ⁽¹⁾
97,9 x 97,9 x 1 Anti-slip Rectificado ⁽²⁾
48,8 x 97,9 x 1 Liso Rectificado ⁽¹⁾
48,8 x 97,9 x 1 Anti-slip
31 x 62,6 x 0,9 Anti-slip



Sophy Beige NEW!

97,9 x 97,9 x 1 Liso Rectificado ⁽¹⁾
97,9 x 97,9 x 1 Anti-slip Rectificado ⁽²⁾
48,8 x 97,9 x 1 Liso Rectificado ⁽¹⁾
48,8 x 97,9 x 1 Anti-slip
31 x 62,6 x 0,9 Anti-slip



Sophy Grey NEW!

97,9 x 97,9 x 1 Liso Rectificado ⁽¹⁾
97,9 x 97,9 x 1 Anti-slip Rectificado ⁽²⁾
48,8 x 97,9 x 1 Liso Rectificado ⁽¹⁾
48,8 x 97,9 x 1 Anti-slip
31 x 62,6 x 0,9 Anti-slip



Coral Sand NEW!

97,9 x 97,9 x 1 Anti-slip Rectificado ⁽¹⁾
48,8 x 97,9 x 1 Anti-slip
31 x 62,6 x 0,9 Anti-slip



Coral Blue NEW!

31 x 62,6 x 0,9 Anti-slip
31,3 x 31,3 (4,9 x 4,9 /u) Mosaico Anti-slip ⁽³⁾

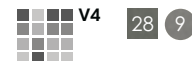

⁽¹⁾Smooth - Rectified / Lisse - Rectifié ⁽²⁾Anti-slip - Rectified / Anti-slip - Rectifié ⁽³⁾Mosaico enmallado de gres porcelánico / Porcelain mesh-mounted mosaic tiles / Mosaïque sur maille en grès cérame

colors & water colors

Los colores del agua
son orientativos

Water colors
are indicative

Les couleurs de l'eau
sont indicatives

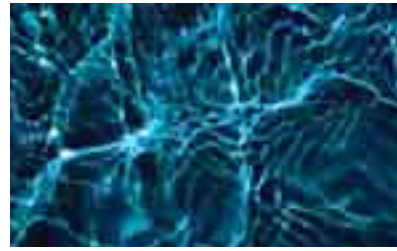

Trésor Bali

31 x 62,6 x 0,9 Anti-slip
31,3 x 31,3 (4,9 x 4,9 /u) Mosaic Anti-slip ⁽¹⁾

Trésor Java

31 x 62,6 x 0,9 Anti-slip
31,3 x 31,3 (4,9 x 4,9 /u) Mosaic Anti-slip ⁽¹⁾



⁽¹⁾ Mosaico enmallado de gres porcelánico / Porcelain mesh-mounted mosaic tiles / Mosaïque sur maille en grès cérame



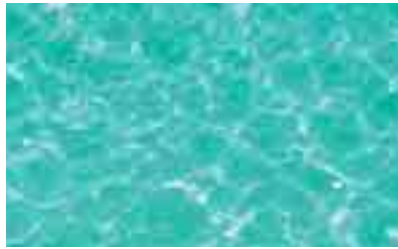
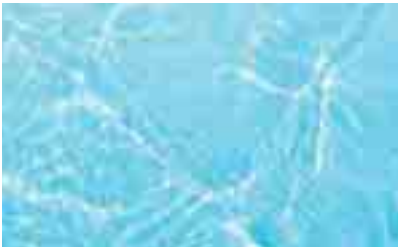

Mythos Selene

48,8 x 97,9 x 1 Anti-slip
48,8 x 97,9 x 1 Liso Rectificado ⁽¹⁾
31 x 62,6 x 0,9 Anti-slip

Mythos Dune

48,8 x 97,9 x 1 Anti-slip
48,8 x 97,9 x 1 Liso Rectificado ⁽¹⁾
31 x 62,6 x 0,9 Anti-slip

Mythos Antique

48,8 x 97,9 x 1 Anti-slip
48,8 x 97,9 x 1 Liso Rectificado ⁽¹⁾
31 x 62,6 x 0,9 Anti-slip

Iconic White

97,9 x 97,9 x 1 Liso Rectificado ⁽¹⁾
97,9 x 97,9 x 1 Anti-slip Rectificado ⁽²⁾
48,8 x 97,9 x 1 Liso - Rectificado ⁽¹⁾
48,8 x 97,9 x 1 Anti-slip
48,8 x 97,9 x 2 Anti-slip - Rectificado ⁽²⁾
31 x 62,6 x 0,9 Anti-slip
31 x 62,6 x 0,9 Pastilla

Iconic Grey

97,9 x 97,9 x 1 Liso Rectificado ⁽¹⁾
97,9 x 97,9 x 1 Anti-slip Rectificado ⁽²⁾
48,8 x 97,9 x 1 Liso - Rectificado ⁽¹⁾
48,8 x 97,9 x 1 Anti-slip
48,8 x 97,9 x 2 Anti-slip - Rectificado ⁽²⁾
31 x 62,6 x 0,9 Anti-slip
31 x 62,6 x 0,9 Pastilla

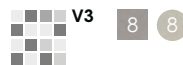

⁽¹⁾Smooth - Rectified / Lisse - Rectifié ⁽²⁾Anti-slip - Rectified / Anti-slip - Rectifié

colors & water colors

Los colores del agua
son orientativos

Water colors
are indicative

Les couleurs de l'eau
sont indicatives

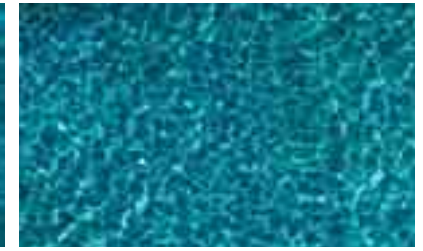

Pietro White

48,8 x 97,9 x 1 Liso - Rectificado ⁽¹⁾
48,8 x 97,9 x 1 Anti-slip
48,8 x 97,9 x 2 Anti-slip - Rectificado ⁽²⁾
31 x 62,6 x 0,9 Anti-slip
31 x 62,6 x 0,9 Pastilla

Pietro Golden

48,8 x 97,9 x 1 Liso - Rectificado ⁽¹⁾
48,8 x 97,9 x 1 Anti-slip
48,8 x 97,9 x 2 Anti-slip - Rectificado ⁽²⁾
31 x 62,6 x 0,9 Anti-slip
31 x 62,6 x 0,9 Pastilla

Pietro Grey

48,8 x 97,9 x 1 Anti-slip
31 x 62,6 x 0,9 Anti-slip
31 x 62,6 x 0,9 Pastilla

Pietro Dark

48,8 x 97,9 x 1 Anti-slip
31 x 62,6 x 0,9 Anti-slip
31 x 62,6 x 0,9 Pastilla

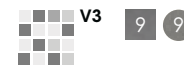
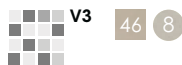

⁽¹⁾Smooth - Rectified / Lisse - Rectifié ⁽²⁾Anti-slip - Rectified / Anti-slip - Rectifié



Serena Bianco

48,8 x 97,9 x 1 Liso Rectificado ⁽¹⁾
48,8 x 97,9 x 1 Anti-slip
31 x 62,6 x 0,9 Anti-slip

Serena Ocra

48,8 x 97,9 x 1 Liso Rectificado ⁽¹⁾
48,8 x 97,9 x 1 Anti-slip
31 x 62,6 x 0,9 Anti-slip

Serena Griggio

48,8 x 97,9 x 1 Anti-slip
31 x 62,6 x 0,9 Anti-slip

Serena Nero

48,8 x 97,9 x 1 Anti-slip
31 x 62,6 x 0,9 Anti-slip

Serena Mix

31 x 62,6 x 0,9 Anti-slip

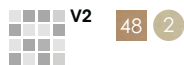

colors & water colors

Los colores del agua
son orientativos

Water colors
are indicative

Les couleurs de l'eau
sont indicatives



Mystery White

48,8 x 97,9 x 1 Anti-slip
48,8 x 97,9 x 1 Liso Rectificado ⁽¹⁾
31 x 62,6 x 0,9 Anti-slip
31 x 62,6 x 0,9 Liso ⁽²⁾
31,3 x 31,3 (4,9 x 4,9 /u) ⁽³⁾ Mosaic Liso ⁽²⁾



Mystery Sand

48,8 x 97,9 x 1 Anti-slip
48,8 x 97,9 x 1 Liso Rectificado ⁽¹⁾
31 x 62,6 x 0,9 Anti-slip
31 x 62,6 x 0,9 Liso ⁽²⁾
31,3 x 31,3 (4,9 x 4,9 /u) ⁽³⁾ Mosaic Liso ⁽²⁾



Mystery Grey

48,8 x 97,9 x 1 Anti-slip
48,8 x 97,9 x 1 Liso Rectificado ⁽¹⁾
31 x 62,6 x 0,9 Anti-slip
31 x 62,6 x 0,9 Liso ⁽²⁾
31,3 x 31,3 (4,9 x 4,9 /u) ⁽³⁾ Mosaic Liso ⁽²⁾



Mystery Blue Stone

48,8 x 97,9 x 1 Anti-slip
48,8 x 97,9 x 1 Liso Rectificado ⁽¹⁾
31 x 62,6 x 0,9 Anti-slip
31 x 62,6 x 0,9 Liso ⁽²⁾
31,3 x 31,3 (4,9 x 4,9 /u) ⁽³⁾ Mosaic Liso ⁽²⁾

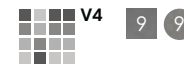



wo od tex tu re



Stela White

19,4 x 97,9 x 1 Anti-slip



Stela Golden

19,4 x 97,9 x 1 Anti-slip

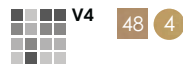

Stela Grey

19,4 x 97,9 x 1 Anti-slip



Stela Dark

19,4 x 97,9 x 1 Anti-slip





Alma Pure

19,4 x 97,9 x 1 Anti-slip

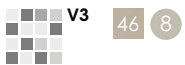

Alma Honey

19,4 x 97,9 x 1 Anti-slip



Alma Forest

19,4 x 97,9 x 1 Anti-slip



Alma Mist

19,4 x 97,9 x 1 Anti-slip



wo
od
tex
tu
re

constructive systems



Sistema desbordante
Deck level pool system
Système à débordement

Minimal 



Sistema desbordante
Deck level pool system
Système à débordement

Ergo Plus 



Sistema desbordante
Deck level pool system
Système à débordement

Prestige



Sistema desbordante
Deck level pool system
Système à débordement

Slim



Sistema desbordante
Deck level pool system
Système à débordement

Smart

constructive systems



Sistema desbordante
Deck level pool system
Système à débordement



Solución Piscina Infinity
Infinity Pool Solution
Solution Piscine Infinity



Sistema Skimmer, solución «L»
Skimmer System, «L» solution
Système Skimmer, solution «L»



Sistema Skimmer, solución «S»
Skimmer System, «S» solution
Système Skimmer, solution «S»



New Look System
New Look System
New Look System

Zen

Minimal NEW!

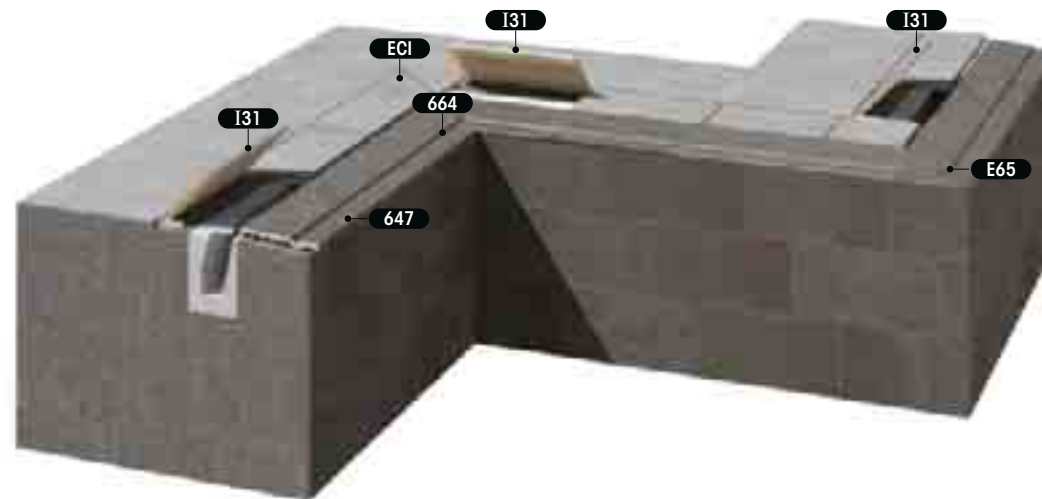

Piezas de borde | Edge tiles | Margelles

I31 Anti-Slip
62,6 x 31 x 2,6

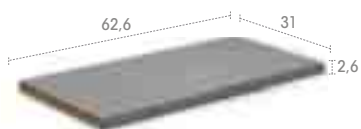

ECI Anti-Slip
34,5 x 34,5 x 2,6

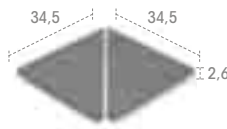

647 Anti-Slip
62,6 x 31 x 2,6

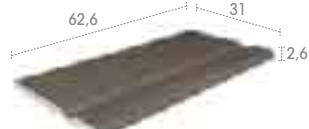

664 Anti-Slip
62,6 x 62,6 x 2,6



NEW! **E65 Anti-Slip**
31 x 31 x 2,6



El único **sistema desbordante oculto con un canal registrable**.
 Instalación sencilla y eficiente. Adaptable a diferentes diseños.
 Estética minimalista. Limpieza extrema.

The **only concealed overflow system with a registrable channel**.
 Simple and efficient installation. Adaptable to different designs.
 Minimalist esthetic. Extreme cleanliness.

L'unique système à débordement caché avec un canal **accessible**.
 Une installation simple et efficace. Adaptable à différents modèles.
 Esthétique minimaliste. Une propreté extrême.

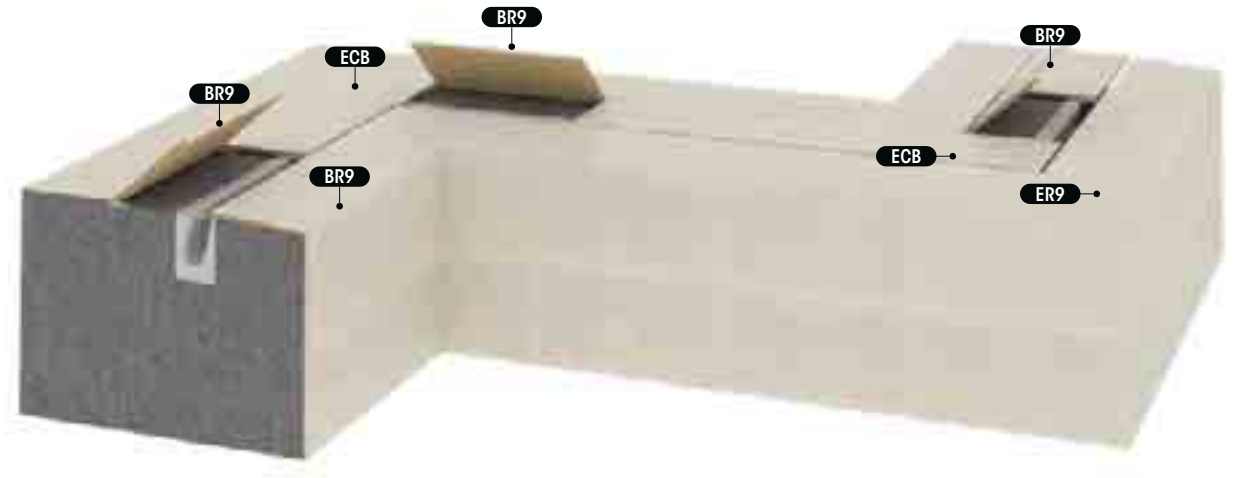

Piezas de borde | Edge tiles | Margelles

BR6 Anti-Slip
 62,6 x 50 x 2,6

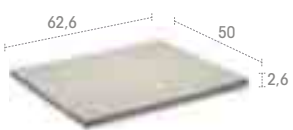

ER6 Anti-Slip
 62,6 x 62,6 x 50 x 2,6

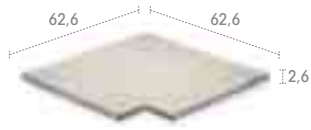

BR9 Anti-Slip
 97,9 x 50 x 2,6

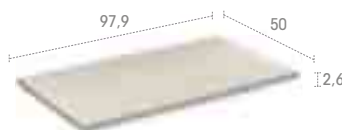

ER9 Anti-Slip
 97,9 x 97,9 x 50 x 2,6

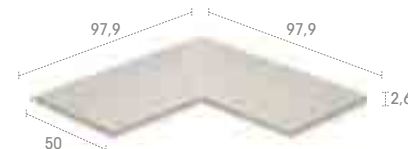

ECB Anti-Slip
 52,8 x 52,8 x 2,6

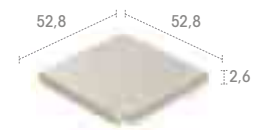

Ergo Plus NEW!

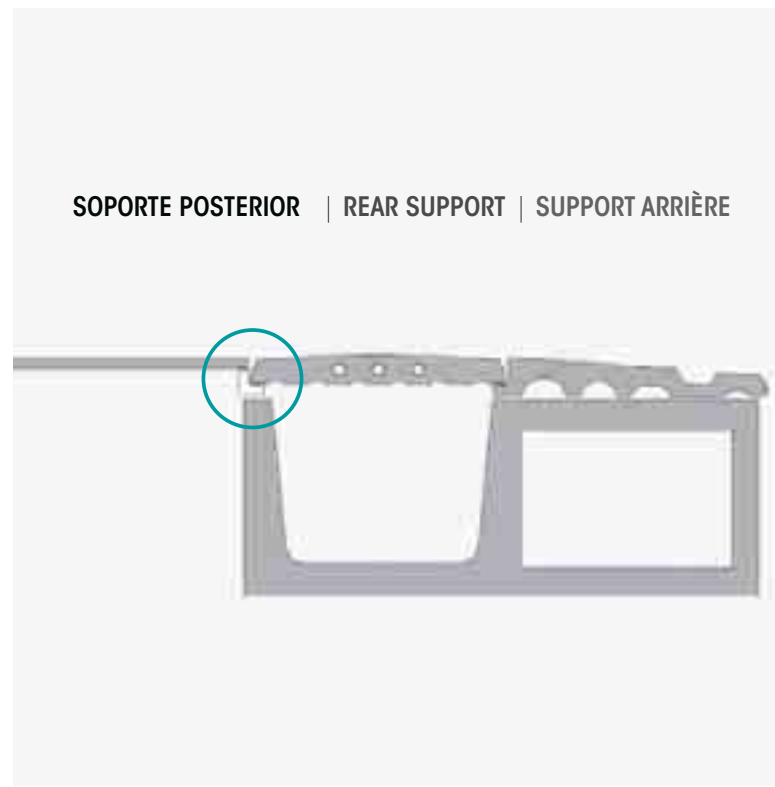
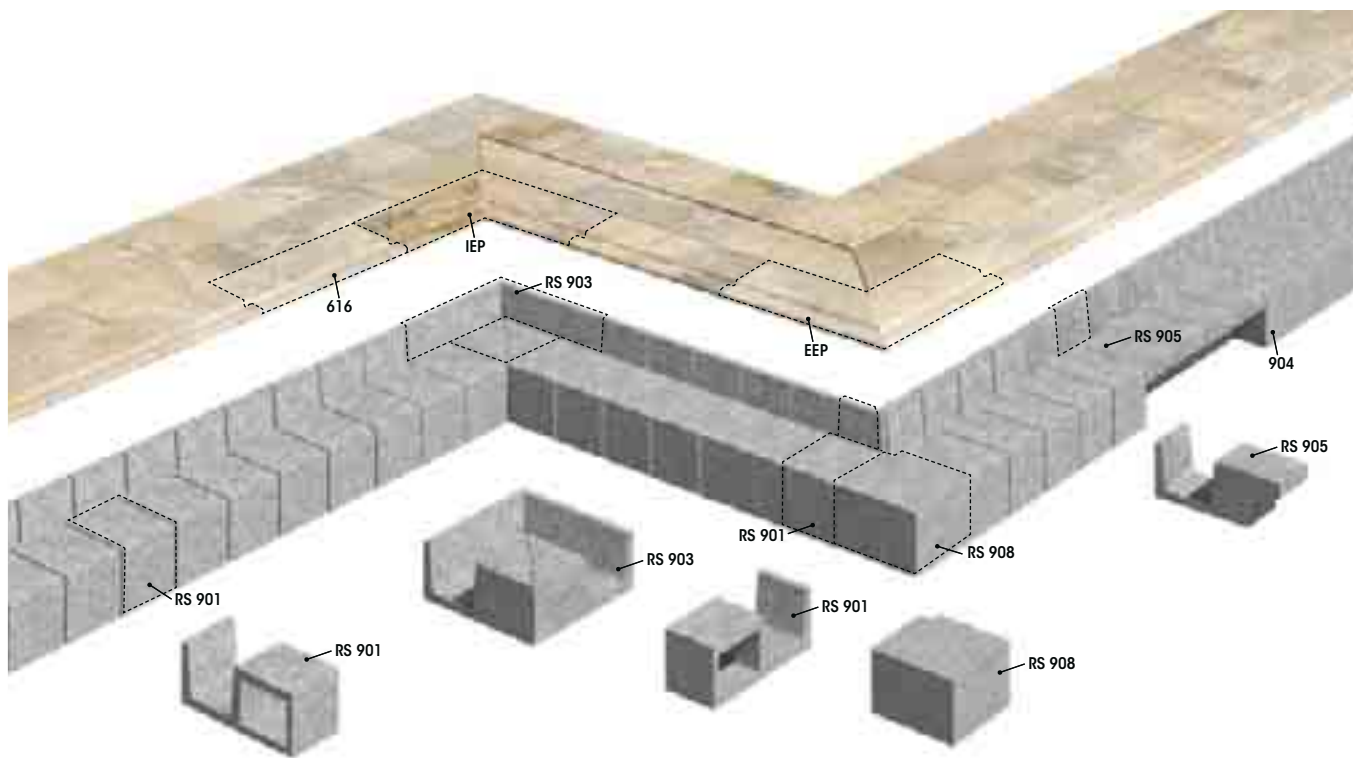

Bloques S9 | S9 Blocks | Modules S9

RS 901
Base

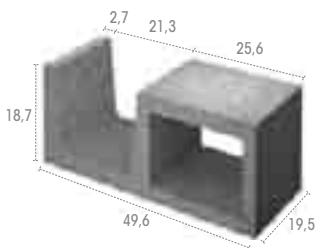

RS 902
Escalera abierta
Open built-in stairs
Échelle ouverte

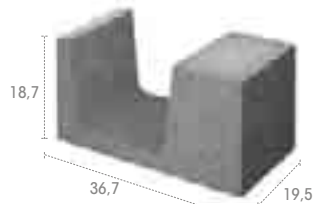

RS 903
Esquina Interior
Inside corner
Angle intérieur

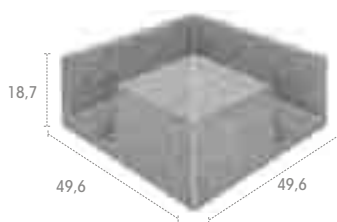

RS 904
Maciza
Solid
Solide

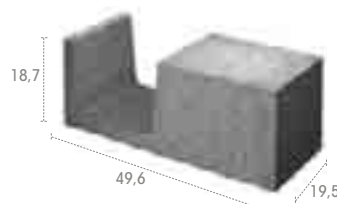

RS 905
Escalera cerrada
Closed built-in stairs
Échelle fermée

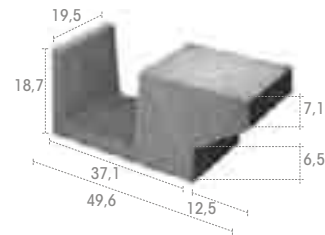

RS 908
Esquina exterior
Outside corner
Angle extérieur

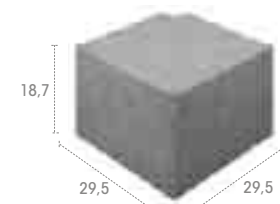

Un nuevo soporte para el apoyo de la rejilla que protege el hormigón de los módulos S9, mejora la construcción y aumenta la vida de la piscina.

It is a new support for the grating that protects the concrete of the S9 modules, streamlines the construction process and increases the pool's lifespan.

Un nouveau support pour le caillebotis qui protège le béton des modules S9, améliore la construction et augmente la durée de vie de la piscine.



Piezas de borde | Edge tiles | Margelles

Soporte | Support

Rejilla Flex | Flex Grid | Grille Flex

616 Anti-Slip

62,6 x 26,2 x 3,7

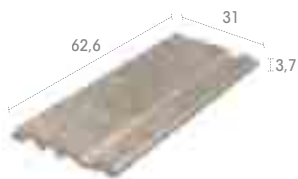

IEP Anti-Slip

62,6 x 62,6 x 3,7



EEP Anti-Slip

62,6 x 62,6 x 3,7



110

24,4 x 2,5



245 FL Anti-Slip

49,5 x 24,5 x 2,2

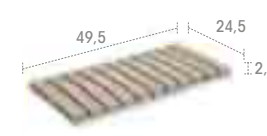

245 EF Anti-Slip

26,6 x 26,6 x 2,2

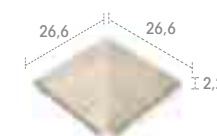

Prestige

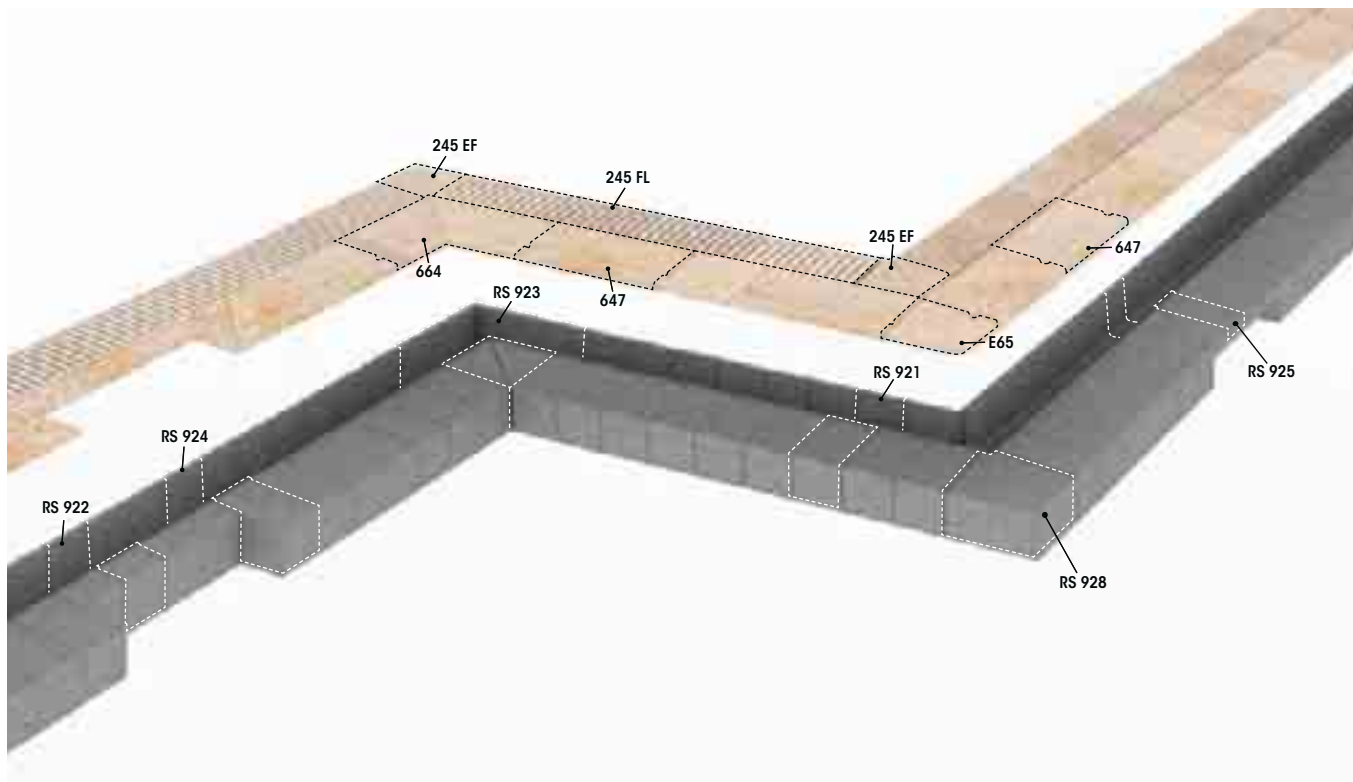

Bloques S9 | S9 Blocks | Modules S9

RS 921

Base

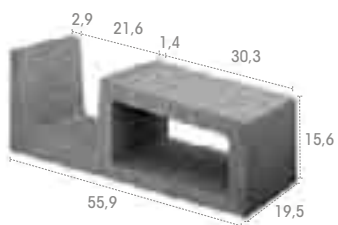

RS 922

Escalera abierta
Open built-in stairs
Échelle ouverte

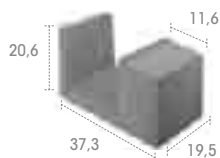

RS 923

Esquina interior
Inside corner
Angle intérieur

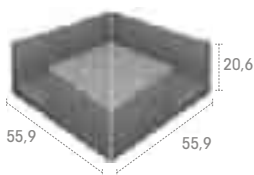

RS 924

Maciza
Solid
Solide

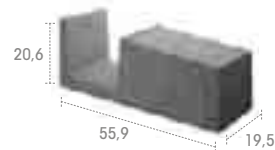

RS 925

Escalera cerrada
Closed built-in stairs
Échelle fermée



RS 928

Esquina exterior
Outside corner
Angle extérieur



Sistema de pre-playa descendente solucionado con la ref. 647 de 31 x 62,7 cm. Los bloques S9 generan la pendiente y funcionan como punto de apoyo para la rejilla del rebosadero.

Downward sloping pre-deck system using ref. 647 measuring 31 x 62.7 cm. S9 blocks provide the slope and support the overflow grate.

Système de débordement avant plage avec pente vers bassin avec la réf. 647 de 31 x 62,7 cm. Les blocs S9 génèrent la pente et servent de point d'appui à la grille de débordement.



Piezas de borde | Edge tiles | Margelles

Rejilla Flex | Flex Grid | Grille Flex

647 Anti-Slip
62,6 x 31 x 2,6

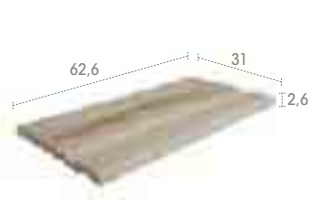

664 Anti-Slip
62,6 x 62,6 x 2,6



NEW! **E65 Anti-Slip**
31 x 31 x 2,6



245 FL Anti-Slip
49,5 x 24,5 x 2,2



245 EF Anti-Slip
26,6 x 26,6 x 2,2



Slim

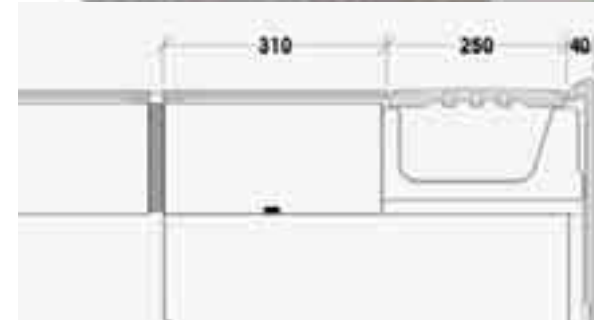
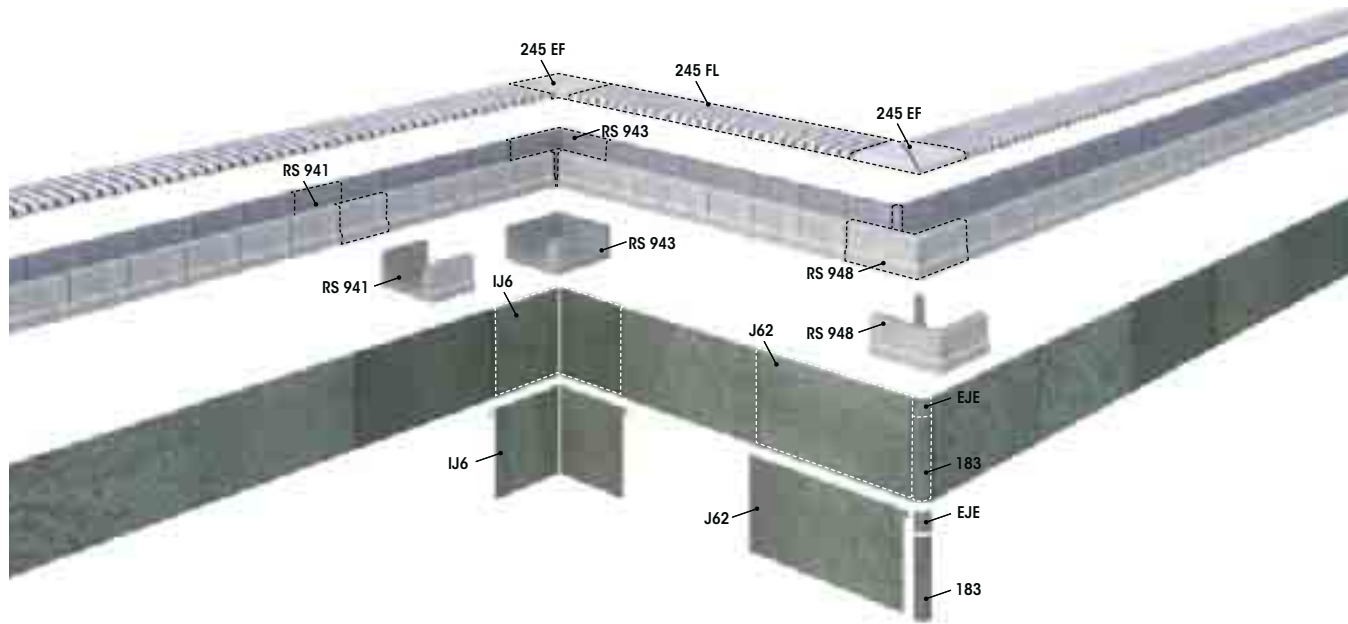

Bloques S9 | S9 Blocks | Modules S9

RS 941
Base

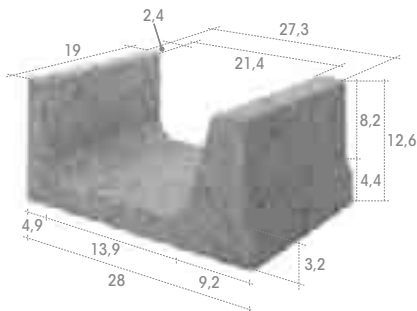

RS 943
Esquina interior
Inside corner
Angle inférieur

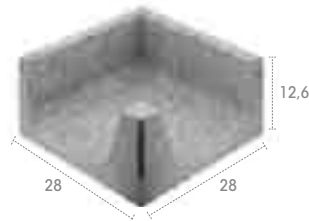

RS 948
Esquina exterior
Outside corner
Angle extérieur

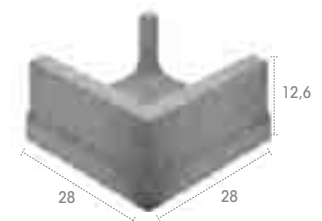

La innovación del Sistema Slim soluciona los proyectos de piscinas desbordantes con playas estrechas de forma práctica y funcional. Su diseño sitúa el nivel del agua por encima del nivel de la playa. Consigue recrear un bonito efecto espejo.

The innovative Slim System is a practical and functional solution for overflow pool projects with limited deck space. The design places the water level above the deck, creating an attractive mirror effect.

L'innovation du Système Slim apporte une solution pratique et fonctionnelle aux projets de piscine à débordement avec un espace de plage réduit. Sa conception situe le niveau de l'eau au-dessus du niveau de la plage et permet de créer un très joli effet miroir.



Piezas de borde | Edge tiles | Margelles

Rejilla Flex | Flex Grid | Grille Flex

J62 Anti-Slip
62,6 x 31 x 3,8

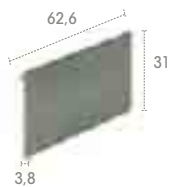

IJ6 Anti-Slip
31 x 31 x 31

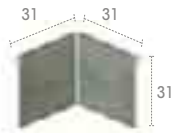

EJ6 Anti-Slip
62,6 x 62,6 x 31

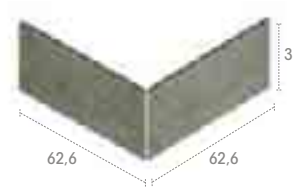

NEW! **EJE**
4 x 4



245 FL Anti-Slip
49,5 x 24,5 x 2,2

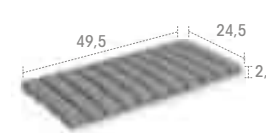

245 EF Anti-Slip
26,6 x 26,6 x 2,2

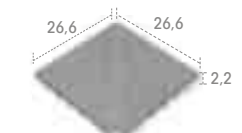

Smart

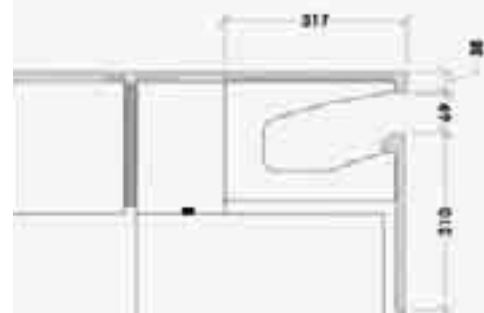
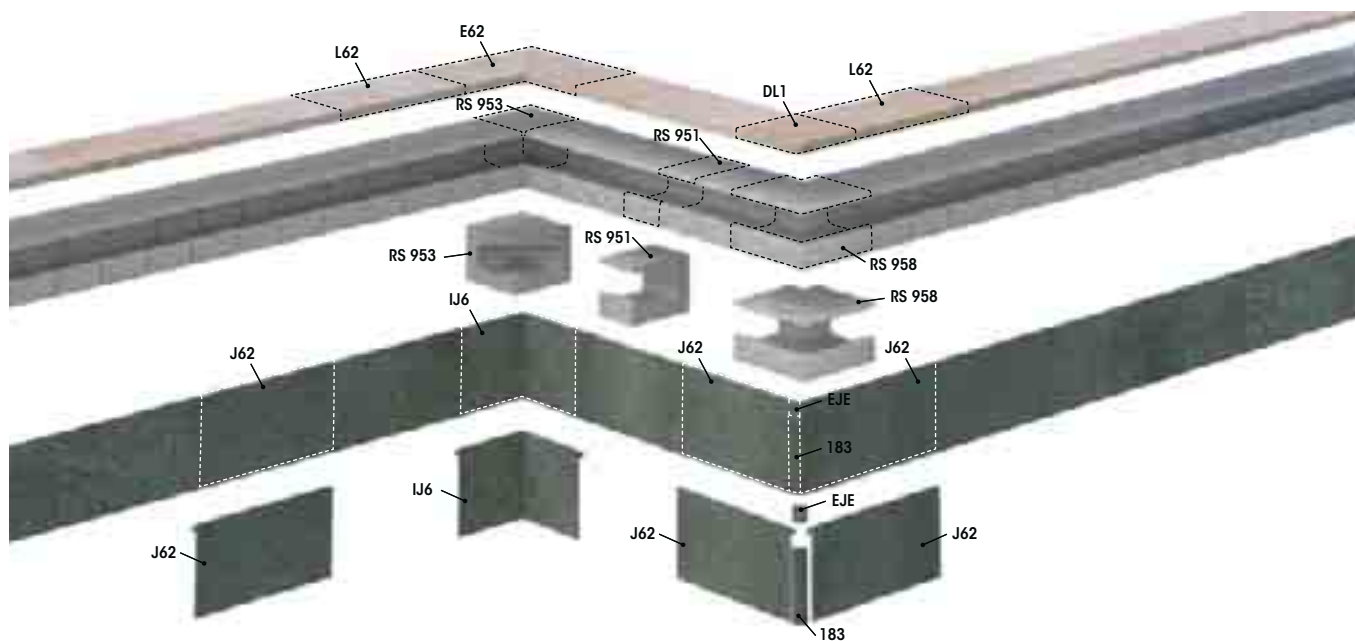

Bloques S9 | S9 Blocks | Modules S9

RS 951

Base

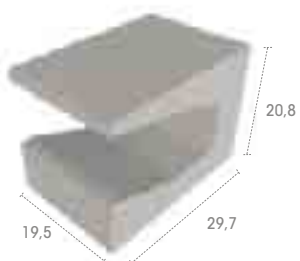

RS 953

Esquina interior
Inside corner
Angle inférieur

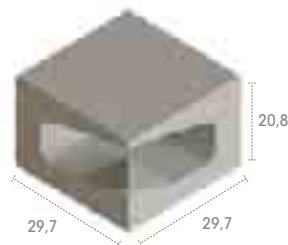

RS 958

Esquina exterior
Outside corner
Angle extérieur

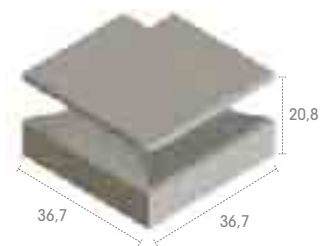

Sistema desbordante longitudinal oculto. Su innovación hace posible que el nivel del agua se sitúe por debajo del nivel de la playa. De esta forma se evita que el agua salga de la piscina. Su diseño ofrece un buen agarre del bañista.

Hidden longitudinal overflow system that allows the water level to remain below deck level. This prevents water from spilling out of the pool. The design also provides a handhold for swimmers.

Il s'agit d'un système à débordement longitudinal invisible. Il permet de maintenir le niveau de l'eau en-dessous de la plage. Il empêche ainsi l'eau de déborder hors de la piscine. Il est conçu de telle façon que les nageurs peuvent s'y agripper commodément.



Piezas de borde | Edge tiles | Margelles

J62 Anti-Slip
62,6 x 31 x 3,8

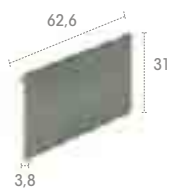

IJ6 Anti-Slip
31 x 31 x 31

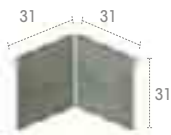

EJ6 Anti-Slip
62,6 x 62,6 x 31

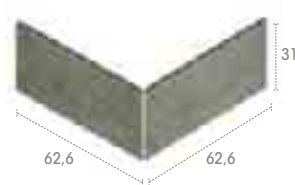

NEW! **EJE**
4 x 4



Zen

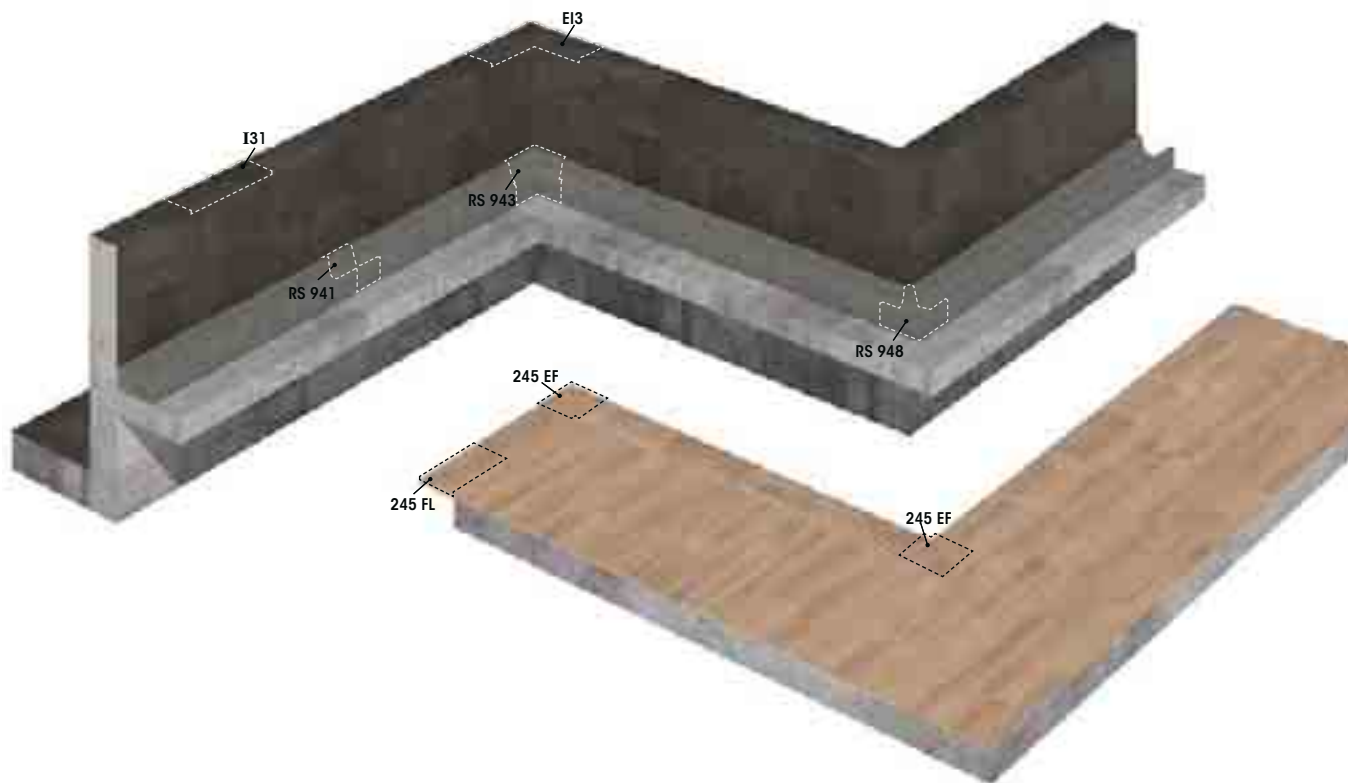

Bloques S9 | S9 Blocks | Modules S9

RS 941

Base

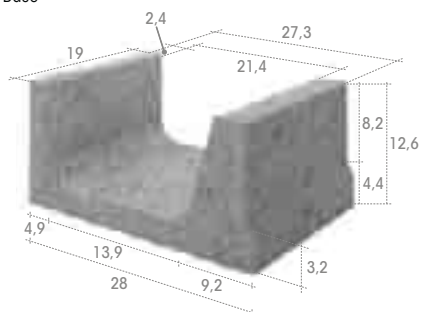

RS 943

Esquina interior
Inside corner
Angle intérieur

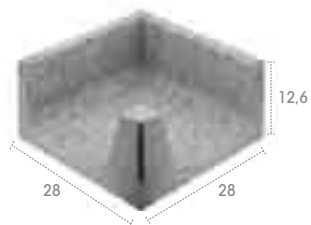

RS 948

Esquina exterior
Outside corner
Angle extérieur

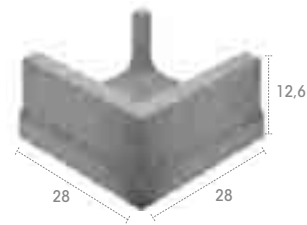

Piscina con desborde perimetral elevado sobre un canal oculto empotrado en la playa. El Sistema Zen es perfecto para construir una original piscina de inspiración balinesa.

Pool with raised perimeter overflow above a hidden channel integrated into the deck. The Zen System is perfect for building an original Balinese-inspired pool.

Piscine à débordement périmétrique surélevé au-dessus d'un canal invisible intégré dans la plage. Le Système Zen est parfait pour construire une piscine originale d'inspiration balinaise.



Piezas de borde | Edge tiles | Margelles

I31 Anti-Slip
62,6 x 31 x 2,6

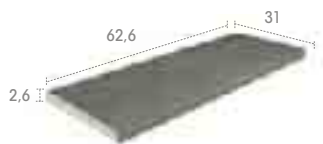

E13
62,6 x 62,6 x 2,6

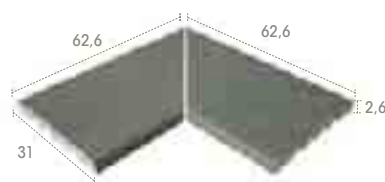



Flex

Compact



Su estructura en forma de trapecio evita el puente de agua incluso cuando está mal colocada. Facilita la reposición de piezas sueltas. Permite realizar curvas a partir de un radio de 75 cm.

Trapezoidal structure allows for perfect water flow even when poorly laid. Loose pieces can be easily repositioned. It can be used to create curves with a radius of more than 75 cm.

Sa structure trapézoïdale permet une parfaite évacuation de l'eau. La mise en place de pièces de remplacement est simplifiée. Permet de réaliser des courbes à partir d'un rayon de 75 cm.

245 FL Anti-Slip

49,5 x 24,5 x 2,2



245 EF Anti-Slip

26,6 x 26,6 x 2,2

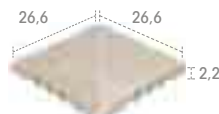

Consiste en una sola pieza fabricada sin adhesivos. Al colocarla queda totalmente integrada con el borde. El desagüe se realiza a través de un sistema de orificios laterales apenas visible y con una capacidad óptima.

Composed of a single piece, without adhesives. Once in place, it blends in perfectly with the edge of the pool. The water is drained through side openings that are barely visible and have optimal capacity.

Elle consiste en une seule pièce, conçue sans adhésifs. Sa mise en place l'intègre totalement au débordement. Le drainage s'effectue à travers les mini canaux latéraux, à peine visibles mais d'une capacité optimale.

245 CM Anti-Slip

62,6 x 24,5 x 2,2

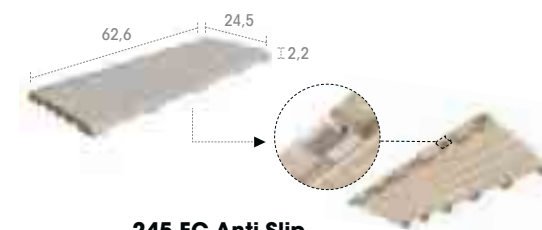

245 EC Anti-Slip

62,6 x 62,6 x 2,2

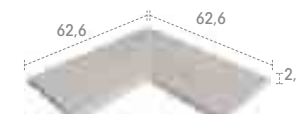

Infinity



Una solución única para construir piscinas Infinity. Se trata de una pieza especial multifunción. La misma pieza sirve para revestir el murete de la piscina y el murete del canal de recogida del agua. Así conseguimos un precioso diseño integrado.

Unique solution for the construction of infinity pools. This is a special multi-purpose piece. The same piece is used to line the walls of the pool and the wall of the water collection channel. This way the edge, pool and walls all match beautifully.

Une solution unique pour la construction de piscines à débordement. Il s'agit d'une pièce spéciale multifonctionnelle. La même pièce peut être utilisée pour couvrir la paroi de la piscine et la paroi du canal de collecte de l'eau. Cela permet de créer un magnifique design intégré.

Piezas | Pieces | Pièces

131 Anti-Slip
62,6 x 31 x 2,6

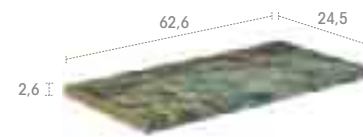

E13 Anti-Slip
62,6 x 62,6 x 2,6

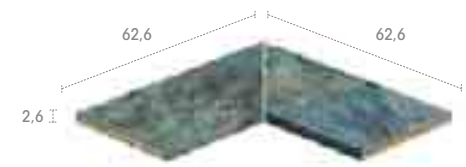

New Look System



BR6 Anti-Slip
62,6 x 50 x 2,6



ER6 Anti-Slip
62,6 x 62,6 x 50 x 2,6



BR9 Anti-Slip
97,9 x 50 x 2,6



ER9 Anti-Slip
97,9 x 97,9 x 50 x 2,6



056
62,6 x 5 x 0,9



E56
5 x 4,3 x 0,9

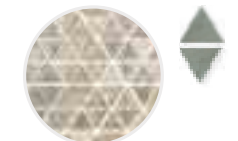

- Material suministrado sin enmallar
- Material supplied unmeshed
- Matériau fourni non maillé

L Solution

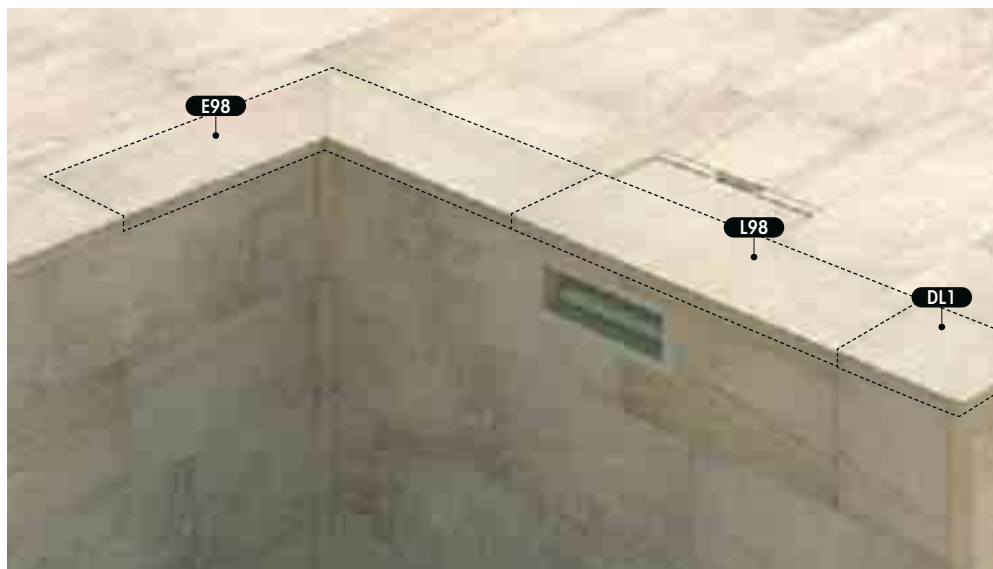

L62 Anti-Slip
62,6 x 31,7 x 3,8

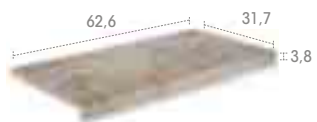

E62 Anti-Slip
62,6 x 62,6 x 3,8

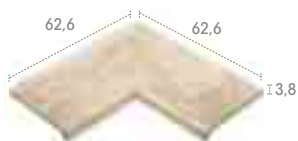

L98 Anti-Slip
97,9 x 31,7 x 3,8

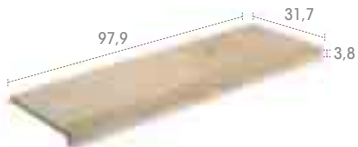

NEW! **E98 Anti-Slip**
97,9 x 97,9 x 3,8



DL1 Anti-Slip
31,7 x 31,7 x 3,8



DL2 Anti-Slip
31,7 x 31,7 x 3,8

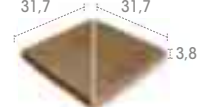

S Solution

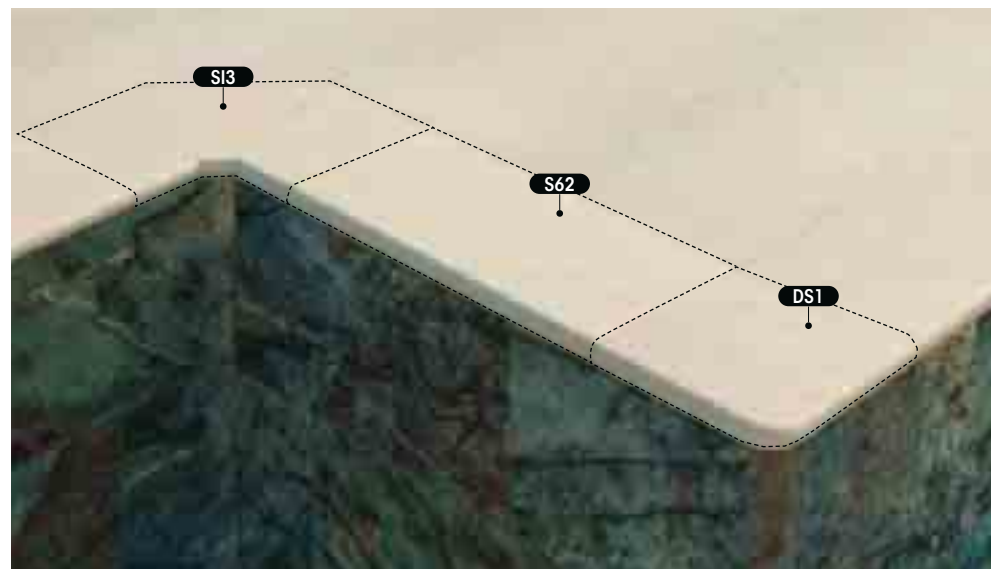

S62 Anti-Slip
62,6 x 31 x 2,6

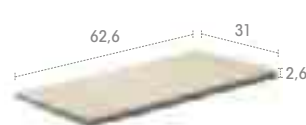

S13 Anti-Slip
46 x 46 x 2,6



DS1 Anti-Slip
31 x 31 x 2,6



SE3 Anti-Slip
31 x 31 x 2,6

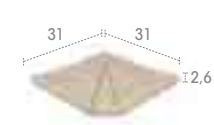

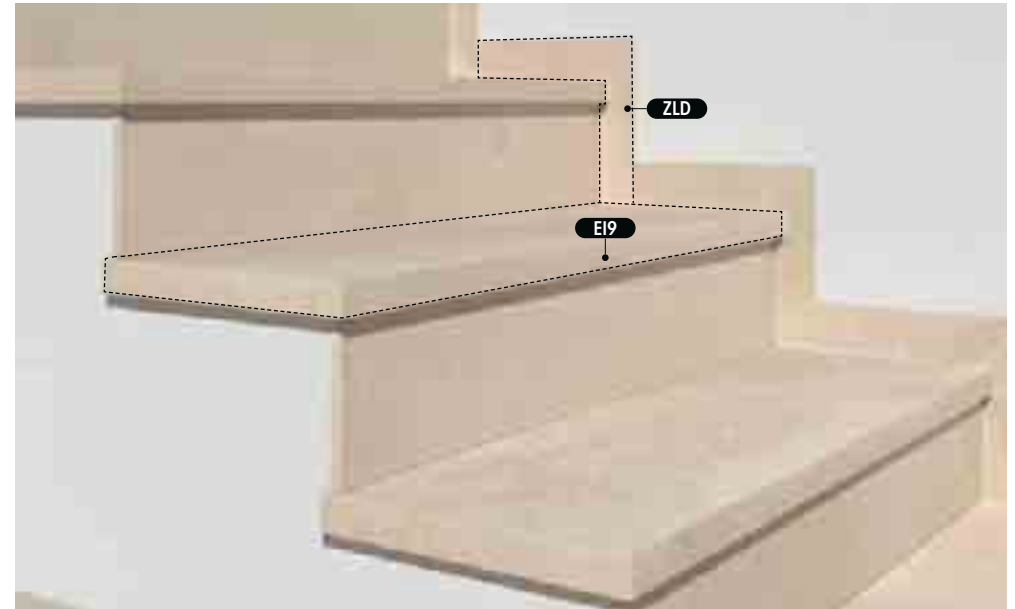
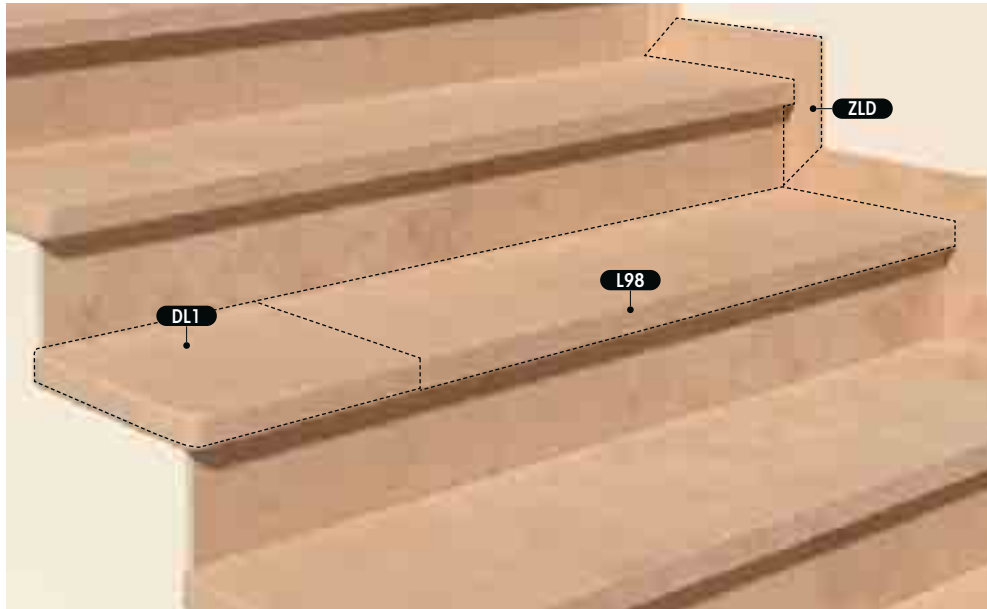

L98 Anti-Slip
97,9 x 31,7 x 3,8

L98 Liso
97,9 x 31,7 x 3,8

L62 Anti-Slip
62,6 x 31,7 x 3,8

EI9 Anti-Slip
97,9 x 31,7 x 3,8

ED9 Anti-Slip
97,9 x 31,7 x 3,8

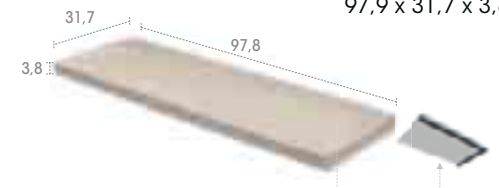
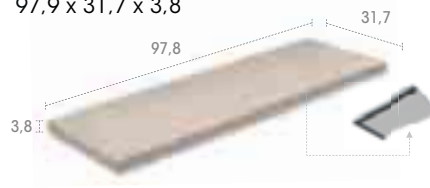
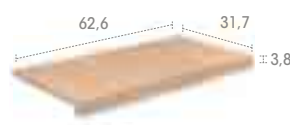
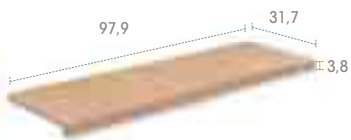
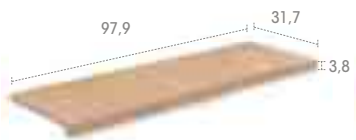

DL1 Anti-Slip
31,7 x 31,7 x 3,8

DL2 Anti-Slip
31,7 x 31,7 x 3,8

Z62
62,6 x 7

ZLI
36,5 x 30 x 7

ZLD
36,5 x 30 x 7

EI9 Liso
97,9 x 31,7 x 3,8

ED9 Liso
97,9 x 31,7 x 3,8

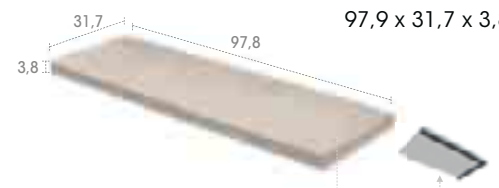
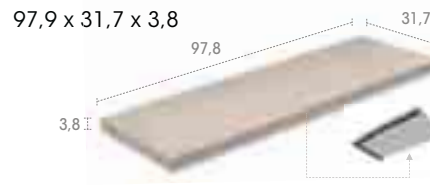
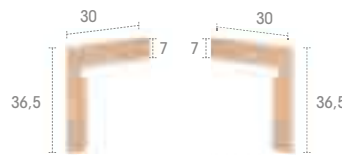
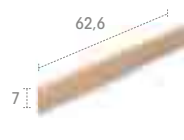
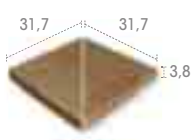
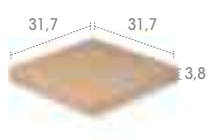

EI6 Anti-Slip
62,6 x 31,7 x 3,8

ED6 Anti-Slip
62,6 x 31,7 x 3,8

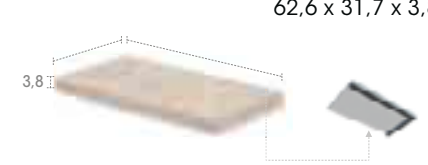
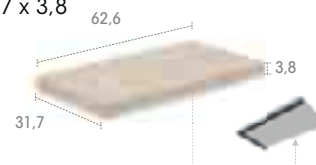



188 Anti-Slip
31 x 4 x 4



183 Anti-Slip
31 x 4 x 4



147 Anti-Slip
31 x 4 x 4

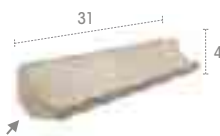

114 Anti-Slip
4 x 4



115 Anti-Slip
4 x 4



116 Anti-Slip
4 x 4

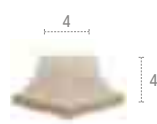

117 Anti-Slip
4 x 4

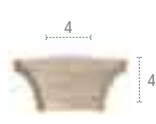

030 Anti-Slip
31 x 4 x 4

Para esquinas interiores
For inner corners
Pour angles intérieurs

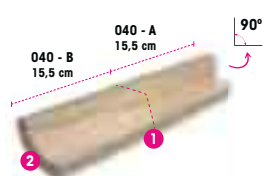

040 Anti-Slip
31 x 4 x 4

Para esquinas exteriores
For outer corners
Pour angles extérieurs

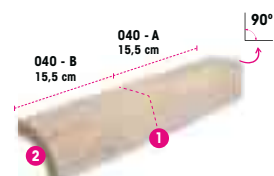

- En estas dos referencias, **030** y **040**, uno de los extremos acaba en un ángulo recto de 90° mientras que el otro acaba en una curva con un radio de 4 cm.

- These two references, **030** and **040**, have a curve with a 4-cm radius on one end and a 90° angle on the other end.

- Ces deux références, **030** et **040**, se terminent à l'une des extrémités par un angle droit de 90°, et à l'autre extrémité par une courbure d'un rayon de 4 cm.

- 1 - Radio igual a DL1 en el centro
- Radius matches DL1 in the centre
- Rayon égal à DL1 au centre
- 2 - Radio: 4 cm
- Radius: 4 cm
- Rayon: 4 cm

121 CM Anti-Slip
62,6 x 12,5 x 2,2



E21
12,5 x 12,5 x 2,2



CRA C1
50 x 13 x 7,5



DCR C1



CCR C1



TCR C1



food and floor the kit chen



**indu
gres**

**100%
Biostop**

La solución más limpia para la cocina industrial

Indugres 100% acabado biostop elimina las bacterias y garantiza la autoprotección de toda la superficie de gres porcelánico más la junta de colocación

Funciona 24 h en interiores y exteriores

Funciona con luz artificial, con luz natural y en completa oscuridad.

Autoprotección total y permanente

La acción auto protectora es permanente y 100% segura. No necesita ningún tratamiento posterior ni mantenimiento para funcionar.

Eficacia probada contra las bacterias

Evita al 100% la proliferación de bacterias como: **Staphylococcus Aureus, Escherichia Coli, Proteus Vulgaris, Salmonella typhi, Enterococcus Faecalis, Streptococcus Pyogenes, Bacillus o Listeria Monocytogenes**

Es gres porcelánico industrial Rosa gres de alta calidad

Su proceso de fabricación garantiza que todas las propiedades del gres porcelánico industrial Rosa Gres se mantienen intactas.

No es tóxico para la salud

Es totalmente inocuo para la salud humana.

Reduce los olores

Evita los malos olores que pueda provocar los depósitos de microorganismos en las superficies.

The cleanest solution for commercial kitchens

Indugres 100% Biostop eliminates bacteria and guarantees self-protection of the entire porcelain stoneware surface including the grout joint.

Works 24 hours indoors and outdoors.

Works in artificial light, natural light and total darkness.

Total and permanent self-protection.

Self-protection is permanent and 100% safe. It does not require any treatment or maintenance.

Proven efficacy against bacteria.

Prevents 100% of bacteria growth such as: **Staphylococcus Aureus, Escherichia Coli, Proteus Vulgaris, Salmonella Typhi, Enterococcus Faecalis, Streptococcus Pyogenes, Bacillus and Listeria Monocytogenes.**

Rosa Gres high-quality industrial porcelain stoneware. The manufacturing process guarantees that all the properties of Rosa Gres industrial porcelain stoneware are maintained.

Not toxic to health.

Completely harmless to human health.

Reduces odors.

Prevents unpleasant odors caused by the accumulation of microorganisms on surfaces.

La solution la plus propre pour les cuisines industrielles

La finition 100% biostop d'Indugres élimine les bactéries et garantit l'autoprotection de toute la surface du grès cérame ainsi que du joint entre les carreaux

Fonctionne 24 heures à l'intérieur et à l'extérieur

Il Fonctionne à la lumière artificielle, à la lumière naturelle et dans l'obscurité totale.

Auto-protection totale et permanente

L'action auto-protectrice est permanente et sûre à 100%. Aucun post-traitement ou entretien n'est nécessaire pour fonctionner.

Efficacité prouvée contre les bactéries

Évite à 100% la prolifération de bactéries telles que : **Staphylococcus aureus, Escherichia coli, Proteus Vulgaris, Salmonella Typhi, Enterococcus faecalis, Streptococcus pyogenes, Bacillus, Listeria monocytogenes**

Grès cérame porcelaine industriel de haute qualité

Son processus de fabrication garantit que toutes les propriétés du grès cérame industriel Rosa Gres restent intactes.

Non toxique pour la santé

Totalement inoffensif pour la santé.

Réduit les odeurs

Évite les odeurs désagréables causées par les dépôts de microorganismes sur les surfaces.



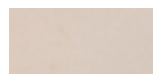

122 G3
11,9 x 24,4 x 1
Indubeige R9

EN16165



ANEXO C ANEXO B



240 G3
24,4 x 24,4 x 1
Indubeige R10

EN16165



ANEXO C ANEXO B ANEXO A

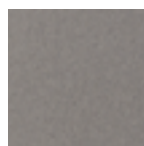

240 G3
24,4 x 24,4 x 1
Indugrey R10

EN16165



ANEXO C ANEXO B ANEXO A



240 G3
24,4 x 24,4 x 1
Indubeige R12

EN16165



ANEXO C ANEXO B ANEXO A

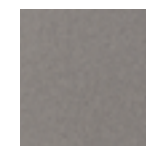

240 G3
24,4 x 24,4 x 1
Indugrey R12

EN16165



ANEXO C ANEXO B ANEXO A

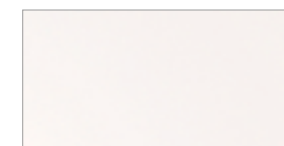

244 G1
24,4 x 49,4 x 0,8
Bio White Liso



Bio-Cerpoxi Blanco
21 KG/U

Bio-Cerpoxi Gris
21 KG/U

Junta de colocación
100% Biostop

Mortero coloreado epoxi con resistencia al ataque de los ácidos y propiedades protectoras: previene el crecimiento de microorganismos perjudiciales para la salud.

Grout Joints
100% Biostop

Coloured epoxy resin resistant to acid and with protective properties: prevents the growth of harmful microorganisms.

Mortier de Jointoiment
100% Biostop

Mortier coloré époxy résistant aux agressions acides et présentant des propriétés protectrices pour empêcher le développement de microorganismes nocifs pour la santé.



Medias cañas | Half round pieces | Demi-Cannes

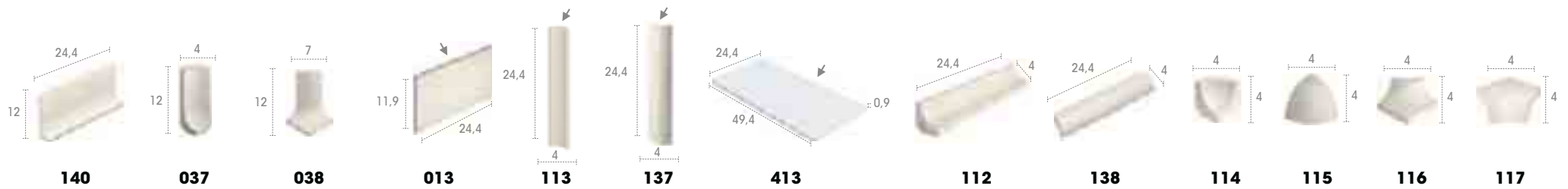
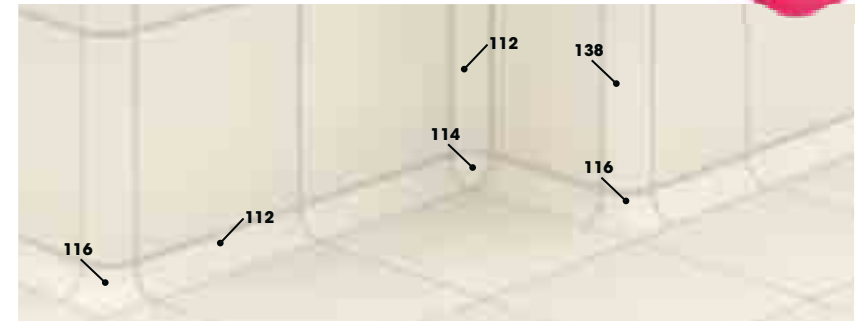
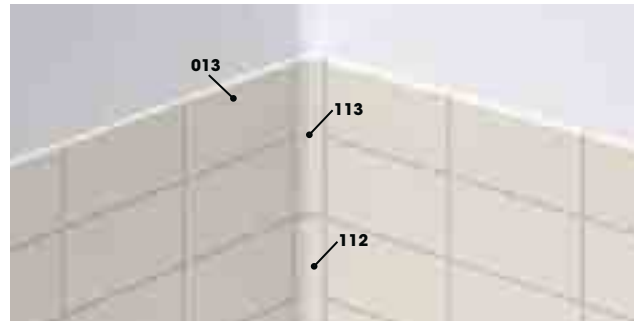
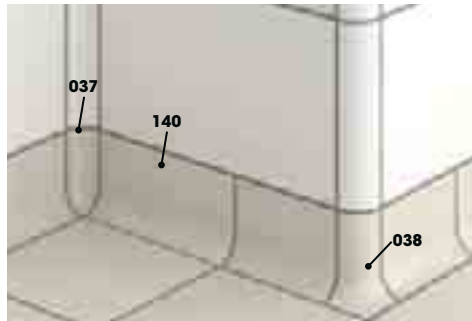

Canaletas | Shallow Chanel | Goulottes

Ducha | Shower | Douche

Peldaños | Steps | Margelles

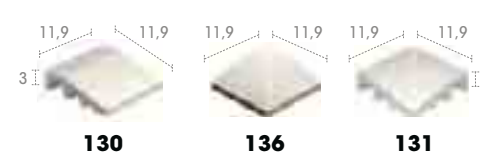
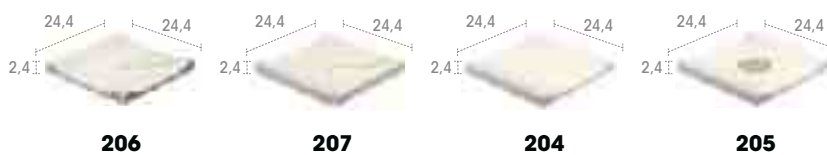
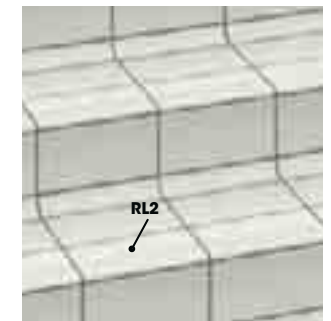
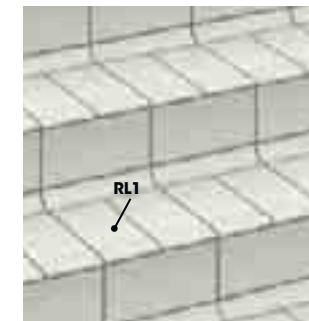
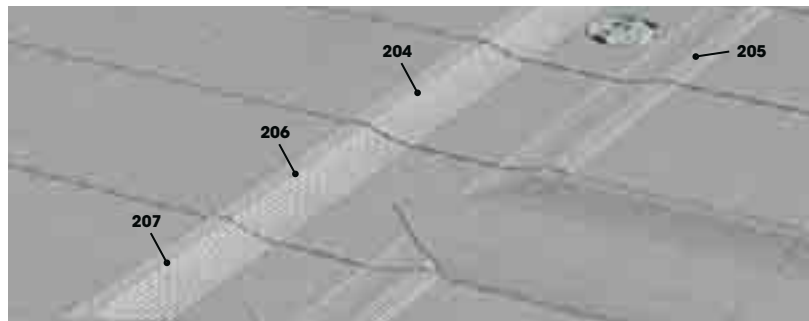

we are eco friendly



VER VÍDEO



WATCH VIDEO



VOIR LA VIDÉO



NUEVA CUBIERTA SOLAR

Instalación fotovoltaica para
el autoconsumo eléctrico

NEW SOLAR ROOF

Photovoltaic system for
self-consumption of electricity

NOUVEAU TOIT SOLAIRE

Installation photovoltaïque pour
autoconsommation électrique



9.435 m²
2.000 Kwp
2.721.099 kwh | AÑO
YEAR
ANNÉE



PROYECTO ZERO NUESTRO COMPROMISO CON EL MEDIO AMBIENTE

El compromiso de **Rosa Gres** por generar el mínimo impacto medioambiental nos llevó a crear un protocolo de Sostenibilidad propio. Es nuestro **Proyecto ZERO** y se basa en los siguientes propósitos:

- Practicar una mejora continuada, de forma transversal en toda la empresa, conscientes del futuro a corto y largo plazo.
- Producir de forma eficiente y controlada para reducir el consumo de recursos naturales.
- No generar residuos durante el proceso de producción: separar, reutilizar, valorizar.
- Prever y controlar el impacto medioambiental del producto **Rosa Gres** una vez acabado: su traslado desde la fábrica, su vida útil y su reciclaje final.

PROGRAMAS PROYECTO ZERO

Zero Vertidos

Reutilizamos el 100% del agua del proceso productivo.

Zero Residuos

Segregamos y reciclamos el 100% de los residuos valorizables.

Reciclaje Non-Stop

Procesamos todos los materiales del ciclo de producción para su reutilización.

Zero Emisiones

- Toda la potencia eléctrica que consume Rosa Gres es de origen renovable. Además se han instalado placas fotovoltaicas en la cubierta de la planta, que generan 2 MW para autoconsumo.
- Optimización mediante el control y gestión on-line de los recursos energéticos.

Construcción industrializada. Ecodiseño

Diseñamos sistemas constructivos que minimizan el residuo en la obra, reducen el tiempo de ejecución y aseguran el resultado final.

CERTIFICACIONES MEDIOAMBIENTALES

Rosa Gres formó parte del comité de desarrollo de la normativa **DAPc®**, la nueva Ecoetiqueta europea de tipo III que permite evaluar el impacto ambiental a lo largo del ciclo de vida del producto y su proceso de fabricación.

La utilización de productos cerámicos, sistemas de construcción y sistemas de colocación **Rosa Gres** aporta puntos para los certificadores LEED, Verde, Breeam y otros.

Rosa Gres es miembro del **GBCe** desde junio de 2010.

PROJECT ZERO OUR COMMITMENT TO THE ENVIRONMENT

Rosa Gres' commitment to minimizing our environmental impact has led us to create our own sustainability protocol, known as **Project ZERO**, which is based on the following objectives:

- Ensure continuous improvement throughout the company, taking into account short and long-term plans.
- Manufacture in an efficient and controlled manner to reduce the consumption of natural resources.
- Avoid waste in the production process by separating, reusing and recycling.
- Anticipate and control the environmental impact of the **Rosa Gres** product once it is finished, including its transfer from the factory, its life span and its final recycling.

PROJECT ZERO PROGRAMS

Zero Water Discharge

We recycle 100% of the water used in the production process.

Zero Waste

We separate and recycle 100% of the recyclable waste.

Non-Stop Recycling

We recycle all materials in the production cycle.

Zero Emissions

- All the electricity used by Rosa Gres comes from renewable sources. In addition, photovoltaic panels have been installed on the roof of the plant, generating 2 MW of self-consumption.
- Optimization through online control and management of energy resources.

Industrialized construction. Ecodesign

We design construction systems that minimize waste during the construction process, reduce execution time and guarantee the final result.

ENVIRONMENTAL CERTIFICATIONS

Rosa Gres was part of the development committee of the **DAPc®** standard, the new European Type III eco-label, which allows us to evaluate environmental impact throughout the life cycle of the product and the manufacturing process.

The use of **Rosa Gres** porcelain stoneware products, construction systems and installation systems can earn points for LEED, Verde, Breeam and other certifiers.

Rosa Gres has been a member of the **GBCe** since June 2010.

PROJET ZÉRO NOTRE ENGAGEMENT POUR L'ENVIRONNEMENT

L'engagement de **Rosa Gres** à générer un impact minimum sur l'environnement nous a conduits à créer notre propre protocole de durabilité. Il s'agit de notre **Projet ZERO** qui se base sur les objectifs suivants :

- Assurer une amélioration continue, de manière transversale, au sein de toute l'entreprise, en étant conscients du futur à court et à long terme.
- Produire de manière efficace et contrôlée afin de réduire la consommation de ressources naturelles.
- Ne pas générer de déchets au cours du processus de production : séparer, réutiliser, valoriser.
- Anticiper et contrôler l'impact environnemental du produit **Rosa Gres** une fois terminé : son transfert depuis l'usine, sa durée de vie et son recyclage en fin de vie.

PROGRAMMES PROJET ZÉRO

Zéro Eau Déversée

Nous recyclons 100% de l'eau utilisée pendant la production.

Zéro Déchet

Nous séparons et recyclons 100% des déchets récupérables.

Recyclage Non-Stop

Nous utilisons tous les matériels du cycle de production en vue de les réutiliser.

Zéro Émission

- Toute l'énergie électrique consommée par Rosa Gres provient de sources renouvelables. De plus, des panneaux photovoltaïques ont été installés sur le toit de l'usine, produisant 2 MW pour l'autoconsommation.

- Optimisation grâce au contrôle et à la gestion en ligne des ressources énergétiques.

Construction industrialisée. Écoconception

Nous concevons des systèmes de construction qui minimisent les déchets sur le chantier, réduisent le temps d'exécution et garantissent le résultat final.

CERTIFICATIONS ENVIRONNEMENTALES

Rosa Gres a fait partie du comité de développement de la norme **DAPc®**, le nouveau label écologique européen de type III qui permet d'évaluer l'impact environnemental tout au long du cycle de vie du produit et de son processus de fabrication.

L'utilisation des produits céramiques, des systèmes de construction et d'installation de **Rosa Gres** permet d'obtenir des points pour les certifications LEED, Verde, Breeam et autres.

Rosa Gres est membre du **GBCe** depuis juin 2010.



LUXURY

Hotel Lasala Plaza, Grupo Sade Hoteles, San Sebastián, Spain

Hotel Maria Cristina, Marriot San Sebastián, Spain

Arantza Hotela - Boutique Hotel Spa Eco, Navarra, Spain

L'Isle de Leos Hotel & Spa, MGallery Collection, France

Hotel Royal Marine suits Lanzarote, Canary Islands, Spain

Le couvent des minimes, L'occitane en provence, Mane, France

Helguera Palacio Boutique Antique Cantabria, Spain

Hotel Palacios de los Ángeles, Majestic Hotel Group, la Rioja, Spain

Palacio de Samaniego, Álava, Spain

Gran Hotel Miramar, Málaga, Spain

Meliá Sierra Nevada, Granada, Spain

Hotel Kimpton Aysla, Palma de Mallorca, Balearic Islands, Spain

Ibiza Bay, Ibiza, Balearic Islands, Spain

Hotel Royal Marine suits Lanzarote, Canary Islands, Spain

Lango Design Hotel & Spa, Kos, Greece

Galgorm Resort and Spa, Galgorm, United Kingdom

Residence Inn by Marriott, Amsterdam, The Netherlands

The Marmorosch, Bucharest, Romania

Kharkiv Palace Hotel, Kyiv, Ukraine

Spa Hotel Villa Ivanovi Dvori, Bičine, Croatia

Hilton Malta Hotel, St Julian's, Malt

Six Senses Kaplankaya, Bodrum, Turkey

Hotel Sun Bat Yam, Bat Yam, Israel

The Jaffa, Luxury Collection Tel Aviv, Israel

Golden Crown Nazareth Hotel, Vladislavova, Israel

Amman Marriot Hotel, Amman, Jordan

Intercontinental Amman, Amman, Jordan

The Ritz-Carlton, Montreal, Canada

Iberostar Grand Hotel Packard, La Habana, Cuba

Hotel Radisson Royal, Panama City, Panama

Hyatt Centric, Guatemala City, Guatemala

El Cielo Hotel, Medellín, Colombia

Theros All Suit Hotel, Kos, Greece

The Fives Ocean Front Puerto Morelos, Puerto Morelos, México

Anamcara Suites, La Palma, Canary Islands, Spain

THEME HOTEL

The WB Abu Dhabi, Curio Collection by Hilton, Abu Dhabi, EAU

Costa Caribe Aquatic Park - Port Aventura, Tarragona, Spain

RESORT

Barceló Costa Ballena Golf & Spa, Cádiz, Spain

Barceló Montecastillo Golf, Jerez de la Frontera, Spain

Barceló Punta Umbría Beach Resort, Punta Umbría, Spain

St. Regis Mardavall Mallorca Resort, Palma de Mallorca, Balearic Islands, Spain

Elba Royal Village Resort, Lanzarote, Canary Islands, Spain





Princess Inspire, Tenerife, Canary Islands, Spain.



Pine Cliffs Resort Algarve, Albufeira, Portugal



Hotel Sheraton Cascais Resort, Cascais, Portugal



| | | | | | |
|---|--|--|--|--|---|
| JW Marriot Venice Resort & Spa, Venice, Italy | Dreams Playa Mujeres Golf & Spa Resort, Quintana Roo, México | Hotel Rozsutek, Terchová, Slovakia | Hotel Mara Sinaia, Sinaia, Romania | Hotel Monte Ulía , San Sebastián, Spain | OREA Hotel Pyramida, Praga, Czech Republic |
| Odyssee Resort Thalasso and Spa Oriental, Zarzis, Tunisia | Melià Paradisus los Cayos, Cayo Santa Maria, Cuba | Resort Sobořín, Sobořín, Czech Republic | RINA Hotel, Sinaia, Romania | Hotel Catalonia Goya , Madrid, Spain | Mercure Kraków Fabryczna City, Kraków, Poland |
| Tui Blue Oceana Suites, Hammamet, Tunisia | Paradisus Varadero Resort & Spa, Varadero, Cuba | HOTEL SPA | Hotel Horizont Resort, Stará Lesná, Slovakia | Pestana Collection Plaza Mayor, Madrid, Spain | Novotel Kinshasa, Kinshasa, Democratic Republic of the Congo |
| TMK Hotel Flora Park Hammamet, Tunisia | Valentín Varadero El Patriarca, Varadero, Cuba | Hotel & Spa Ciutat de Binèfar Huesca, Spain | Hotel Impozant Valcianska Dolina, Valča, Slovakia | Hotel Chiqui Santander, Cantabria, Spain | East Hotel Miami, Swire Hotels, Miami, USA |
| Hilton Rijeka Costabella, Beach Resort & Spa, Rijeka, Croatia | Iberostar Playa Pilar, Cayo Guillermo, Cuba | Souki ~ Lodges & Spa Cabrières, France | Hotel Termal Vyhne, Vyhne, Slovakia | Hotel La Corza Blanca, Cantabria, Spain | CAMPING |
| Kanika Hotels & Resorts, Limassol, Cyprus | RURAL | Kit Space Hotel Et Spa, Ile de France, France | Terme Olimia D.D., Podčetrtek, Slovenia | Hotel Barceló Punta Cana, Barceló Hotel Group, República Dominicana | Camping & Resort Sangulí, Salou, Tarragona, Spain |
| Amavi Hotel, Paphos, Cyprus | Posada Trebuesto, Cantabria, Spain | Gran Hotel de la Toja, Eurostars Isla de la Toja, Spain | SPA Orkana, Lublin, Poland | Hotel La Palma Llanes, Asturias, Spain | Camping La Plage, Argelès-sur-Mer, France |
| Hotel Meliá Durres, Gjiri, Albania | La Maison Papillons, Montclus France | Balneario de Mondariz, Mondariz, Spain | Uvildy Resort, Karabash, Russia | Hotel Villa de Benavente, Zamora, Spain | HOLIDAY HOTEL |
| Orea Resort Santon, Brno-Bystrc, Czech Republic. | Posada de Doña Urraca, Zamora Spain | Hotel Palasiet - Wellness clinic and Thalasso, Benicassim, Spain | Hotel Grand Kopaonik, Kopaonik, Serbia | Hotel Paseo de la Fe, Eurostars, San Sebastián, Spain | Best Costa Ballena, Chipiona, Cádiz, Spain |
| Complex Hotelier Steaua de Mare, Eforie Nord, Romania | Hotel Palacio Torre de Ruesca, Akla Hoteles Vizcaya, Spain | Aqua Hotel Silhouette & Spa, Malgrat de Mar, Barcelona, Spain | HDV Reina del Mar, Obzor, Bulgaria | Hotel Les Hautes Mers, Les Domaines de Fontenille, L'Île-d'Yeu, France | Hotel Helios Mallorca, Palma de Mallorca, Balearic Islands, Spain |
| Royalton Grenada, Saint George, Grenada | Malates Slow Boutique Hotel, Foz, Lugo, Spain | Spa Hotel Attica 21, Vigo, Spain | Hotel Balneari Vichy Catalan, Caldes de Malavella, Girona, Spain | Brown Eilat, Eilat, Middle East | Maritim Antonine Hotel & Spa, Mellieha, Malta |
| Mamula Island Hotel, Mamula Island, Montenegro | Hotel SomniFabrik, Valderrobles Teruel, Spain | Le Petit Beaumarchais, París, France | URBAN | Hotel Les Voyageurs, Cadena Brit Loudeac, France | Hotel Splendid Becici, Budva, Montenegro |
| Lopesan Costa Bávaro Resort, Spa & Casino, Punta Cana, Dominican Republic | Casa Rural Boutique Palacio Condes de Cirac, La Rioja, Spain | Spa Naantali, Naantali, Finland | Hotel Pompaelo Urban Spa ****, Pamplona, Spain | Hotel Ininside Palma Center, Mallorca, Balearic Islands, Spain | Hotel Splendid Becici, Budva, Montenegro |
| Sandos Playacar, Playa del Carmen, México | Parador Nacional Costa da Morte, Muxía, A Coruña, Spain | Hotel Europa Fit, Hévíz, Hungary | Hotel Barceló Costa Vasca, Barceló Hotel Group, San Sebastián, Spain | COCO-MAT Hotel, Atenas, Greece | Hotel Fontanellas Playa, Palma de Mallorca, Balearic Islands, Spain |
| Royal Uno Resort & Spa, Cancún, México | Hotel Pazo O Rial, Villagarçía de Arousa, Pontevedra, Spain | Hotel Horal Wellness & Spa Hotel, Radhoštská, Czech Republic | Axel Hotel, San Sebastián, Spain | Intercity Hotel Amsterdam Airport, Amsterdam, The Netherlands | Hotel EETU, Begur, Spain |
| Secrets Playa Mujeres Golf & Spa Resort, Cancún, México | Panoráma Hotel, Štrba, Slovakia | Spa Hotel Svoboda, Mariánské Lázně, Czech Republic | Student TSH, San Sebastián, Spain | Hotel Middelburg, Middelburg, The Netherlands | Hotel Núria, Tarragona, Spain |

EN 16165

| | | | |
|---|---|----------------|--------------|
| ANEXO C  AN. 2.6 |  | CLASS 0 | Rd < 15 |
| |  | CLASS 1 | 15 < Rd ≤ 35 |
| |  | CLASS 2 | 35 < Rd ≤ 45 |
| |  | CLASS 3 | Rd > 45 |

| | | | |
|---|---|------------|-------------|
| ANEXO B  DIN 51130 NP P-05-010 PIE CALZADO FOOTWEAR PIED CHAUSSÉ |  | R9 | > 6° - 10° |
| |  | R10 | > 10° - 19° |
| |  | R11 | > 19° - 27° |
| |  | R12 | > 27° - 35° |

| | | | |
|--|--|----------------|------|
| ANEXO A  DIN 51097 NP P-05-010 PIE DESCALZO BARE FEET PIEDS NUS |  | CLASS A | ≥12° |
| |  | CLASS B | ≥18° |
| |  | CLASS C | ≥24° |

| CORRESPONDANCE DES NORMES PIEDS NUS | |  | CORRESPONDANCE DES NORMES PIEDS CHAUSSÉS | |  |
|-------------------------------------|--------------------|---|--|--------------------|---|
| Normes Française | Normes européennes | | Normes Française | Normes européennes | |
| PNG | ≥6° | | PC6 | R9 | ≥6° |
| PN12 | A ≥12° | | PC10 | R10 | ≥10° |
| PN18 | B ≥18° | | PC20 | R11 | ≥20° |
| PN24 | C ≥24° | | PC27 | R12 | ≥27° |

EN 16165

| Colores Colors Couleurs | Acabado Finish Finition | ANEXO C | | | ANEXO B | | | ANEXO A | | ANSI A 326.3 (ANSI A137-1) |
|-------------------------------|-------------------------------|---------|---------|---------|--------------------------|----------|----------|--------------------------|-----------------|-------------------------------|
| | | AN. 2.6 | | | DIN 51130 NP P-05-010 | | | DIN 51097 XP P-05-010 | | |
| | | Class 1 | Class 2 | Class 3 | R10/PC10 | R11/PC20 | R12/PC27 | Class B PN18 | Class C PN24 | |
| cuore | Anti-slip | | | ● | | ● | | | ● | > 0.55 |
| coral | | | | ● | | ● | | | ● | |
| sophy | | | | ● | | ● | | | ● | |
| mythos | | | | ● | | ● | | | ● | |
| iconic | | | | ● | | ● | | | ● | |
| iconic 2 cm | | | | ● | | ● | | | ● | |
| trésor | | | | ● | ● | | | | ● | |
| stela | | | | ● | | ● | | | ● | |
| pietro | | | | ● | | ● | | | ● | |
| pietro 2 cm | | | | ● | | ● | | | ● | |
| serena | | | | ● | | ● | | | ● | |
| alma | | | | ● | | ● | | | ● | |
| mistry | | | | ● | | ● | | | ● | |
| aqua | | | | ● | | | ● | | ● | |
| iconic | Pastilla | | | ● | | ● | | ● | - | |
| pietro | Pastilla | | | ● | | ● | | ● | | |
| indugres | Pastilla | | | ● | | | | ● | | |
| cuore | Liso Smooth Lisse | ● | | | | | | | | > 0.42 |
| sophy | | ● | | | | | | | | |
| mythos | | ● | | | | | | | | |
| iconic | | ● | | | | | | | | |
| pietro | | ● | | | | | | | | |
| serena | | ● | | | | | | | | |
| mistry | | ● | | | | | | | | |
| indugres | Indubeige R10 | | ● | | ● | | | ● | | - |
| | Indubeige R12 | | | ● | | | ● | ● | | |
| | Indugrey R10 | | | ● | ● | | | ● | | |
| | Indugrey R12 | | | ● | | | ● | ● | | |



Características técnicas | Technical characteristics | Caractéristiques techniques

| | | | | | |
|---|---|---|---|--|-----------------|
| NORMA DE ENSAYO TESTING STANDARD NORME D'ESSAI | NORMATIVA REGULATION RÉGLEMENTATION EN 14411 ISO 13006 | Cuore Coral Sophy Mythos Iconic Trésor | Stela Pietro Serena Alma Mistery | Pietro 2 cm Iconic 2 cm | Indugres |
|---|---|---|---|--|-----------------|

Características dimensionales | Dimensions and surface quality | Dimensions et aspect de la surface

| | | | | | | |
|--|----------------------|---|-------------------------------|---------------------------------------|---------------------------------------|---------------------------------------|
| | ISO 10545 - 2 | Características dimensionales Dimensions and surface quality Dimensions et aspect de la surface | Exigida Required Exigée | Garantizada Guaranteed Garantie | Garantizada Guaranteed Garantie | Garantizada Guaranteed Garantie |
|--|----------------------|---|-------------------------------|---------------------------------------|---------------------------------------|---------------------------------------|

Propiedades físicas | Physical properties | Propriétés physiques

| | | | | | | |
|--|-----------------------|--|--|---------------------------------------|---------------------------------------|---------------------------------------|
| | ISO 10545 - 3 | Absorción de agua Water absorption Absorption d'eau | $E \leq 0,5 \%$ | $E \leq 0,5 \%$ | $E \leq 0,5 \%$ | $E \leq 0,5 \%$ |
| | ISO 10545 - 4 | Fuerza de rotura Breaking strength Effort à la rupture | $\geq 1.300 \text{ N}$ | $\geq 1.300 \text{ N}$ | $\geq 8.000 \text{ N}$ | $\geq 1.300 \text{ N}$ |
| | | Resistencia a la flexión Modulus of rupture Résistance à la flexion | Grupo A1a 28 N/mm ² Grupo B1a 35 N/mm ² | $\geq 35 \text{ N/mm}^2$ | $\geq 35 \text{ N/mm}^2$ | $\geq 40 \text{ N/mm}^2$ |
| | ISO 10545 - 9 | Resistencia al choque térmico Thermal shock resistance Résistance aux chocs thermiques | Exigida Required Exigée | Garantizada Guaranteed Garantie | Garantizada Guaranteed Garantie | Garantizada Guaranteed Garantie |
| | ISO 10545 - 12 | Resistencia a la helada Frost resistance Résistance au gel | Exigida Required Exigée | Garantizada Guaranteed Garantie | Garantizada Guaranteed Garantie | Garantizada Guaranteed Garantie |

Piezas base / Field tiles / Pièces de base: **grupo B1a**

Piezas especiales / Trim pieces / Pièces spéciales: **grupo A1a**

Propiedades químicas | Chemical properties | Propriétés chimiques

| | | | | | | |
|--|-----------------------|--|--------------|---------------------------------------|---------------------------------------|---------------------------------------|
| | ISO 10545 - 13 | Resistencia química ⁽¹⁾ Chemical resistance ⁽¹⁾ Résistance chimique ⁽¹⁾ | Min. Clase B | A LA HA | A LA HA | A LA HA |
| | ISO 10545 - 14 | Resistencia a las manchas Stain resistance Résistance aux taches | Min. Clase 3 | Garantizada Guaranteed Garantie | Garantizada Guaranteed Garantie | Garantizada Guaranteed Garantie |

⁽¹⁾ Excepto ácido fluorhídrico y sus compuestos / Except hydrofluoric acid and its components / À l'exception de l'acide fluorhydrique et de ses composés



Portada y contraportada | Cover and back cover | Couverture et quatrième de couverture: **Sabàtic Sitges Hotel, Spain**



Rosa Gres, SLU

Oficina Central - Central office - Bureau Central

Ctra. Sant Cugat, km. 3

08290 Cerdanyola, Barcelona, Spain

Tel. + 34 93 586 30 60

Ventas: + 34 93 586 37 00

Export Sales: + 34 93 586 37 02

info@rosagres.com

www.rosagres.com

Fábrica - Factory - Fabrique

Pol. Ind. Mas Vell

Ramón Sugrañes, 1

43144 Vallmoll, Tarragona, Spain

Rosa Gres France, SARL

64140 Lons, France

Tel. + 00 33 411 92 00 30

contact@rosagres.com

administration@rosagres.com

www.rosagres.com/fr

Octubre 2025

